

# Service Manual

 **PIONEER**  
The Art of Entertainment

PION-03376



ORDER NO.  
ARP2298

## COMPACT DISC PLAYER

# PD-75

### PD-75 HAS THE FOLLOWING :

Type	Power Requirement	Remarks
KU/CA	AC 120 V only	
HEM	AC 220 V-230 V, AC 230-240 V(switchable)*	
SD	AC 110 V, 120 V-127 V, 220 V, 240 V(switchable)	

\* Change the connection of the power transformer's primary wiring.

- This manual is applicable to PD-75/KU/CA, HEM and SD types.
- As to the HEM and SD types, refer to page 87.
- Ce manuel pour le service comprend les explications de réglage en français.
- Este manual de servicio trata del método ajuste escrito en español.

## CONTENTS

1. SAFETY INFORMATION .....	2	6. REGLAGES .....	54
2. EXPLODED VIEWS AND PARTS LIST .....	4	6. AJUSTES .....	69
3. PACKING .....	13	7. IC INFORMATION .....	84
4. SCHEMATIC DIAGRAM AND .....	14	8. FOR HEM AND SD TYPES .....	87
P.C. BOARDS CONNECTION DIAGRAM		9. PANEL FACILITIES .....	89
5. P.C.B.'s PARTS LIST .....	35	10. SPECIFICATIONS .....	91
6. ADJUSTMENTS .....	39		

**PIONEER ELECTRONIC CORPORATION** 4-1, Meguro 1-Chome, Meguro-ku, Tokyo 153, Japan  
**PIONEER ELECTRONICS SERVICE INC.** P.O. Box 1760, Long Beach, California 90801 U.S.A.  
**PIONEER ELECTRONICS OF CANADA, INC.** 505 Cochrane Drive, Markham, Ontario L3R 8E3 Canada  
**PIONEER ELECTRONIC [EUROPE] N.V.** Keetberglaan 1, 9120 Beveren, Belgium  
**PIONEER ELECTRONICS AUSTRALIA PTY. LTD.** 178-184 Boundary Road, Braeside, Victoria 3195, Australia TEL: [03] 580-9911  
© **PIONEER ELECTRONIC CORPORATION 1991**

FI JUNE 1991

This service manual is intended for qualified service technicians; it is not meant for the casual do-it-yourselfer. Qualified technicians have the necessary test equipment and tools, and have been trained to properly and safely repair complex products such as those covered by this manual.

Improperly performed repairs can adversely affect the safety and reliability of the product and may void the warranty. If you are not qualified to perform the repair of this product properly and safely, you should not risk trying to do so and refer the repair to a qualified service technician.

#### WARNING

Lead in solder used in this product is listed by the California Health and Welfare agency as a known reproductive toxicant which may cause birth defects or other reproductive harm (California Health & Safety Code, Section 25249.5).

When servicing or handling circuit boards and other components which contain lead in solder, avoid unprotected skin contact with the solder. Also, when soldering do not inhale any smoke or fumes produced.

## 1. SAFETY INFORMATION

(FOR USA MODEL ONLY)

### 1. SAFETY PRECAUTIONS

The following check should be performed for the continued protection of the customer and service technician.

#### LEAKAGE CURRENT CHECK

Measure leakage current to a known earth ground (water pipe, conduit, etc.) by connecting a leakage current tester such as Simpson Model 229-2 or equivalent between the earth ground and all exposed metal parts of the appliance (input/output terminals, screwheads, metal overlays, control shaft, etc.). Plug the AC line cord of the appliance directly into a 120V AC 60Hz outlet and turn the AC power switch on. Any current measured must not exceed 0.5mA.

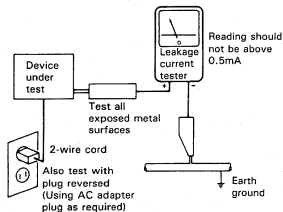

AC Leakage Test

ANY MEASUREMENTS NOT WITHIN THE LIMITS OUTLINED ABOVE ARE INDICATIVE OF A POTENTIAL SHOCK HAZARD AND MUST BE CORRECTED BEFORE RETURNING THE APPLIANCE TO THE CUSTOMER.

### 2. PRODUCT SAFETY NOTICE

Many electrical and mechanical parts in the appliance have special safety related characteristics. These are often not evident from visual inspection nor the protection afforded by them necessarily can be obtained by using replacement components rated for voltage, wattage, etc. Replacement parts which have these special safety characteristics are identified in this Service Manual.

Electrical components having such features are identified by marking with a  $\Delta$  on the schematics and on the parts list in this Service Manual.

The use of a substitute replacement component which does not have the same safety characteristics as the PIONEER recommended replacement one, shown in the parts list in this Service Manual, may create shock, fire, or other hazards.

Product Safety is continuously under review and new instructions are issued from time to time. For the latest information, always consult the current PIONEER Service Manual. A subscription to, or additional copies of, PIONEER Service Manual may be obtained at a nominal charge from PIONEER.

## (FOR EUROPEAN MODEL ONLY)

## VARO!

AVATTAESSA JA SUOJALUKITUS  
OHITETTAESSA OLET ALTTIINA  
NÄKYMÄTTÖMÄLLE LASERSÄTEILYLLE.  
ÄLÄ KATSO SÄTEESEEN.

## ADVERSEL:

USYNLIG LASERSTRÅLING VED ÅBNING  
NÅR SIKKERHEDSAFBRYDERE ER UDE AF  
FUNKTION UDGÅ UDSÆTTELSE FOR  
STRÅLING.

## VARNING!

OSYNLIG LASERSTRÅLING NÅR DENNA  
DEL ÄR ÖPPNAD OCH SPÄRREN  
ÄR URKOPPLAD. BETRakta EJ STRÅLEN.



LASER  
Kuva 1  
Lasersäteilyn  
varoituserkki

## WARNING!

DEVICE INCLUDES LASER DIODE WHICH  
EMITS INVISIBLE INFRARED RADIATION  
WHICH IS DANGEROUS TO EYES. THERE IS  
A WARNING SIGN ACCORDING TO PICTURE  
1 INSIDE THE DEVICE CLOSE TO THE LASER  
DIODE.



LASER  
Picture 1  
Warning sign for  
laser radiation

## IMPORTANT

THIS PIONEER APPARATUS CONTAINS  
LASER OF HIGHER CLASS THAN 1.  
SERVICING OPERATION OF THE APPARATUS  
SHOULD BE DONE BY A SPECIALLY  
INSTRUCTED PERSON.

## LASER DIODE CHARACTERISTICS

MAXIMUM OUTPUT POWER: 5 mw  
WAVELENGTH: 780-785 nm

## LABEL CHECK

## HEM type



CLASS 1  
LASER PRODUCT

VRW-328

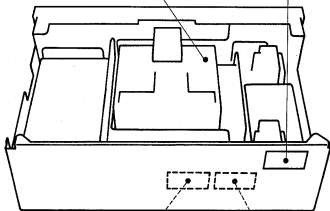

ADVARSEL  
USYNLIG LASERSTRÅLING VED ÅBNING NÅR SIKKERHEDSAFBRYDERE ER UDE AF FUNKTION. UDSÆTTELSE FOR STRÅLING.  
VORSICHT!  
UNSICHTBARE LASERSTRÅLUNG TRITT AUS, WENN DECKEL ODER KLAPPE GEÖFFNET IST NICHT ODER STRAHLEN AUSGEZEIGT.  
VRW1004

VARO!  
Avatessa ja suojelukitus ohitettaessa olet alttiina näkyttömälle lasersäteilylle. Älä katso säteeseen.  
VARNING!  
Osynlig laserstrålning när denna del är öppnad och spärren är urkopplad. Betrakta ej strålen.  
PRW1023

## HEM type

## Additional Laser Caution

## 1. Laser Interlock mechanism

The ON/OFF status of the clamp switch (S 102) for detecting loading completion is detected by the system microprocessor, and the design prevents laser diode oscillation when the clamp switch is OFF.

Thus, the interlock will no longer function if the clamp switch (S 102) is deliberately shorted.

In the test mode the interlock mechanism will not function (refer to page 39).

Laser diode oscillation will continue if pin 4, 5, or 29 of CXA 1081 S(IC 1) is connected to ground or the terminals of Q 304 are shorted each other (fault condition).

## 2. If the fault condition described in 1 is induced with the

cover removed and the objective lens extending past the outer circumference of the disc clamper diameter, close viewing of the objective lens with the naked eye will cause exposure to a Class 1 or higher laser beam.

## 2. EXPLODED VIEWS AND PARTS LIST

### NOTES:

- Parts without part number cannot be supplied.
- Parts marked by "⊗" are not always kept in stock. Their delivery time may be longer than usual or they may be unavailable.
- The  $\Delta$  mark found on some component parts indicates the importance of the safety factor of the part. Therefore, when replacing, be sure to use parts of identical designation.

### 2.1 EXTERIOR

#### Parts List of Exterior

Mark	No.	Description	Parts No.	Mark	No.	Description	Parts No.
	1	Strain relief	CM-22C		41	E-ring	YE30FUC
$\Delta$	2	AC power cord	PDG1015		42	Turntable	PAN1203
$\Delta$	3	Power transformer(16VA)	PTT1166		43	Floating spring	PBH1092
$\Delta$	4	Power transformer(17VA)	PTT1162		44	Rotor assembly	PXA1392
	5	Stopper	PNM1095		45	Screw	BBZ30P060FCC
	6	Tape	PNM1099		46	TT sheet	PNM1125
	7	Stopper	PNM1107		47	SH screw	PBA1033
	8	Bonnet	PEA1168		48	Top panel	PAN1123
	9	• • • • •			49	Side board (L)	PMM1039
	10	• • • • •			50	Side board (R)	PMM1040
	11	Screw	IBZ30P060FCC		51	Wood collar	PNW1238
	12	Cord clammer	RNH-184				
	13	Power button	PAC1539		101	PCB mould	
	14	Tray plate (A) assembly	PXA1395		102	Rear base	
	15	Screw	BBZ30P080FCC		103	Under base	
	16	Screw	IBZ30P060FCC		104	Side angle	
	17	Screw	PMZ30P060FCU		105	Shield plate	
	18	Screw	IBZ30P180FMC		106	Switch angle	
	19	Screw	BBZ40P060FCC		107	Angle (B)	
	20	Screw	BBT30P080FCC		108	• • • • •	
	21	Screw	PDZ30P050FCC		109	Base	
⊗	22	MAIN BOARD assembly	PWZ1983		110	PCB spacer	
⊗	23	ANALOG BOARD assembly	PWM1364		111	Single mechanism assembly	
	24	Screw	PBA1038		112	Tray assembly	
	25	Front panel assembly	PEA1177		113	Plate spring	
	26	Screw	IBZ30P150FCU		114	Board angle	
	27	Screw	IBZ30P060FCC		115	• • • • •	
	28	Screw	BBZ30P140FCC		116	PRIMARY BOARD assembly	
	29	Screw	BBZ30P080FCC		117	Stopper rubber	
	30	• • • • •			118	• • • • •	
	31	Ground plate	PBK1090		119	Stopper tape	
	32	Caution label	PRW1244		120	Tray locker	
	33	Screw	BBZ30P160FZK		121	Collar	
	34	Turntable assembly	PEA1159		122	Slide guide	
	35	Over tray	PNW1871		123	Rack	
	36	Floating screw	PBA1064		124	Tray	
	37	Spindle base assembly	PXA1405		125	Binder holder	
	38	Receptacle	VNL-268		126	Spacer	
	39	Stopper			127	Bonnet spacer	
	40	Damper rubber	PEB1146		128	Wood spacer	

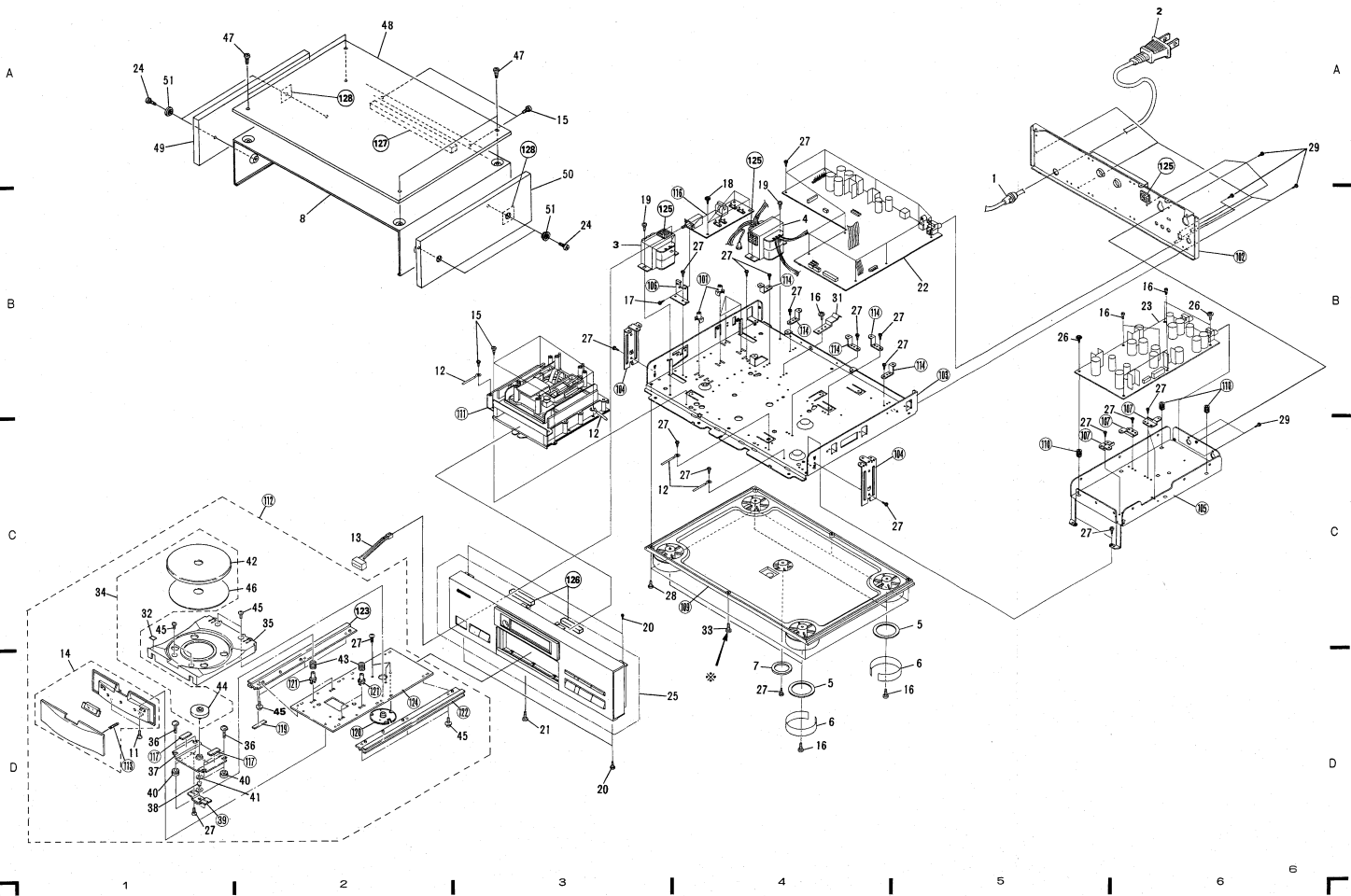

1 | 2 | 3 | 4 | 5 | 6

A

B

C

D

1 | 2 | 3 | 4 | 5 | 6

2.2 FRONT PANEL SECTION

Parts List of Front Panel section

Mark	No.	Description	Parts No.
Δ	1	25P shield F.F.C	PDD1096
	2	Digital burton	PAC1530
	3	FL sheet	PAM1290
	4	Display window(A)	PAM1515
	5	Side sash	PAN1220
	6	Function panel	PNW2065
	7	Lens(L)	PNW1860
	8	Lens(S)	PNW1893
	9	Screw	BBZ26P080FCC
●	10	FUNCTION A BOARD assembly	PWZ2000
	11	Function button	PAC1609
	12	LED cover (S)	PEB1167
	101	Name plate	
	102	Front panel	
	103	LED cover	PEB1150
	104	FUNCTION B BOARD assembly	

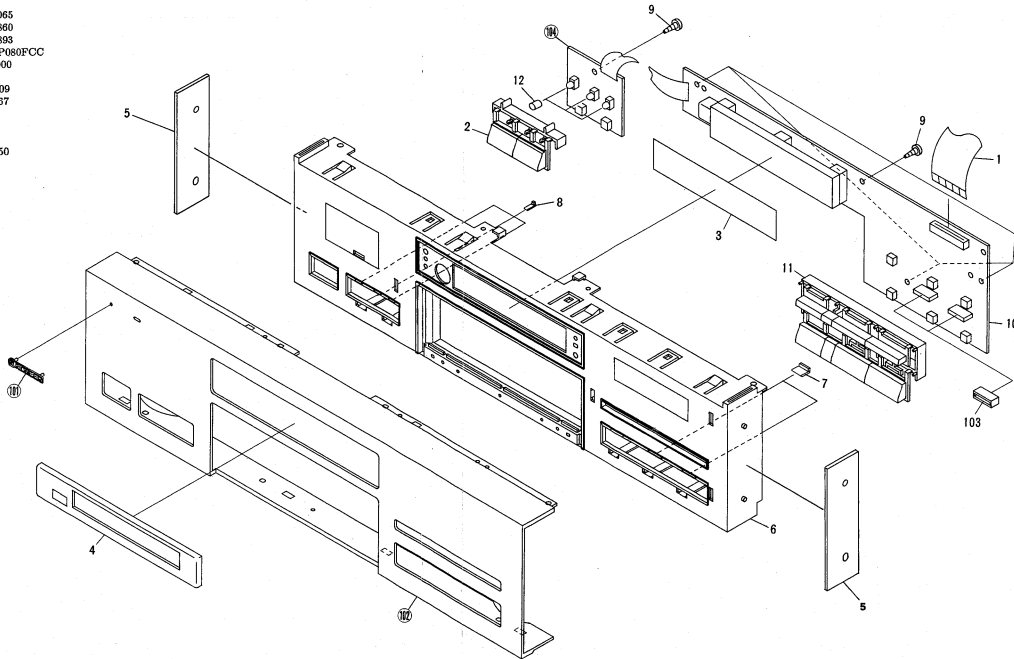

## 2.3 REAR PANEL SECTION

## Parts List of Rear Panel section

Mark	No.	Description	Parts No.
	1	Balance cover	PAT1004
	2	Balance case	PNS1019
	3	.....	
A	4	Screw	BBZ30P080FCC
	5	Screw	BBT30P080FZK
	6	Screw	PMZ26P060FZK
	7	3P receptacle	PKP1004
	101	BALANCE BOARD assembly	
	102	Balance angle	
	103	.....	
	104	Rear base	
	105	Edge cover	

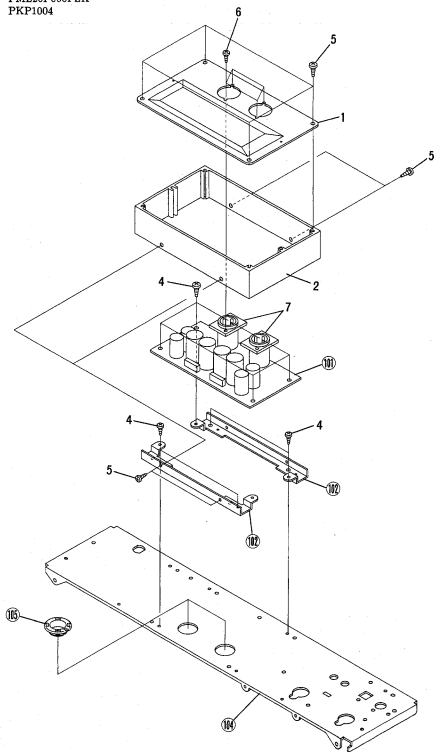

## 2.4 MECHANISM SECTION

### Parts List of Mechanism section

Mark	No.	Description	Parts No.	Mark	No.	Description	Parts No.
	1	Lever switch	DSK1003		51	Ground plate	PDF1087
	2	Floating screw	PBA1064		52	Washer	WT32D080D050
	3	Floating spring (A)	PBH1098		53	Washer	PMA26P040FCU
	4	Floating spring (B)	PBH1099		54	Screw	BPZ26P060FCU
	5	Bias spring	PHB1112		55	Screw	BPZ26P060FMC
	6	Floating spring (C)	PBH1113		56	Screw	WT31D054D013
	7	Floating spring (D)	PBH1114		57	Washer	IBZ30P060FCC
	8	Belt	PEB1138		58	Screw	ZMD30H040FBT
	9	Dumper rubber	PEB1146		59	Screw	PDZ30P060FCC
	10	Stopper rubber	PEB1085		60	Screw	
	11	Screw	PMZ30P350FCU		101	Roller	
	12	Roller	PNW2037		102	Felt	
	13	Blind sheet			103	Synchro gear axis	
	14	Gear	PNW1097		104	Synchro gear axis	
	15	Motor pulley	PNW1643		105	Gear angle	
	16	Cam	PNW1816		106	Mechanism deck	
	17	Synchro gear	PNW1817		107	Bottom plate	
	18	Gear pulley	PNW1870		108	Base plate	
	19	Single gear	PNW1878		109	Collar	
	20	Lock plate	PNW2013		110	U guide	
	21	Loading base (L)	PNW2050		111	Servo mechanism assembly	
	22	Loading base (R)	PNW2051		112	Collar	
	23	DC motor	PXM1010		113	Cushion rubber (2.5)	
	24	Cord clamper	RNH-184		114	Magnet	
	25	Screw	PBA1024		115	Side yoke	
	26	Adjustment screw	PBA1054		116	Center yoke	
	27	Lever spring	PBH1028		117	Vinyl Sheet	
	28	Axis spring	PBH1029		118	Tape	
	29	Adjustment spring	PBK1021		119	Flexible cable	
	30	Rivet	PBM-015		120	Carriage	
	31	Stopper rubber	PEB1035		121	Bobbin (A)	
	32	Rubber	PEB1048		122	Bobbin (B)	
	33	Guide bar	PLA1026		123	Mechanism base unit	
	34	Axis	PLA1027		124	Binder	
	35	Disk table	PLA1088				
	36	Roller	PLM1001				
	37	Adjustment lever	PNB1048				
	38	Spindle motor	PXM1026				
	39	Pick up assembly	PWY1004				
	40	Screw	BBZ30P060FCC				
	41	Screw	IBZ30P080FCC				
	42	Screw	PMZ26P030FCU				
	43	Screw	PMZ26P060FCU				
	44	Screw	PMZ30P080FCU				
	45	Screw	PMZ30P160FCU				
	46	Washer	WS30FMC				
	47	Washer	WT26D047D025				
	48	Screw	ZMD30H040FBT				
	49	Drive unit	PYY1038				
	50	Speed detection unit	PYY1039				

#### • How to install the disc table

- 1 Use nippers or other tool to cut the two sections marked ④ in figure 1. Then remove the spacer.
- 2 While supporting the spindle motor shaft with the stopper, put spacer on top of the motor base (angled so it doesn't touch section ④), and stick the disc table on top (takes about 9kg pressure). Take off the spacer.

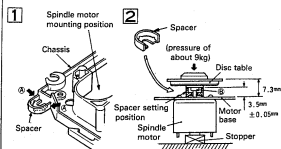



A

Pin No.	Pin Voltage	Pin No.	Pin Voltage	Pin No.	Pin Voltage	Pin No.	Pin Voltage
1	0.3-0.4	17	5	33	1.3	49	-2.0-9
2	0	18	5	34	4.9	50	-2.0-9
3	4.9	19	5	35	4.9	51	-2.0-9
4	4.9	20	5	36	1.3	52	-2.0-9
5	5.1	21	5	37	1.3	53	-2.0-9
6	0	22	5	38	5	54	-2.0-9
7	0.3-0.4	23	5	39	-2.4	55	-2.0-9
8	0	24	0	40	-2.1	56	-2.0-9
9	0	25	0	41	5.1	57	-2.6
10	2.6	26	0	42	0.6	58	0
11	0	27	0	43	5	59	0
12	2.8	28	5	44	-2.4	60	2.3
13	0	29	5	45	1.6	61	2.2
14	0	30	0	46	-2.3	62	5
15	0	31	0	47	-2.0	63	5
16	5	32	0	48	-2.0	64	5

Pin No.	Pin Voltage	Pin No.	Pin Voltage	Pin No.	Pin Voltage	Pin No.	Pin Voltage
0	0	17	0	33	5	49	0.2-0.3
1	5	18	5	34	5	50	0
2	1.9	19	5	35	0	51	0
3	0	20	0	36	5	52	0
4	0	21	0	37	5	53	0
5	2.9	22	0	38	5	54	0
6	4.9	23	0	39	4.9	55	0
7	0	24	0	40	0	56	0
8	0	25	0	41	0.3-0.4	57	0
9	0	26	0	42	0	58	0
10	0	27	0	43	0	59	0
11	0	28	0	44	0	60	0
12	0	29	0	45	0	61	0
13	0	30	0	46	0	62	0
14	0	31	0	47	0	63	0
15	0	32	0	48	0	64	2.5

1 C A 01 (P D G 0 3 6)

P D 3 1 7 9 B)

B

C

D

E

F

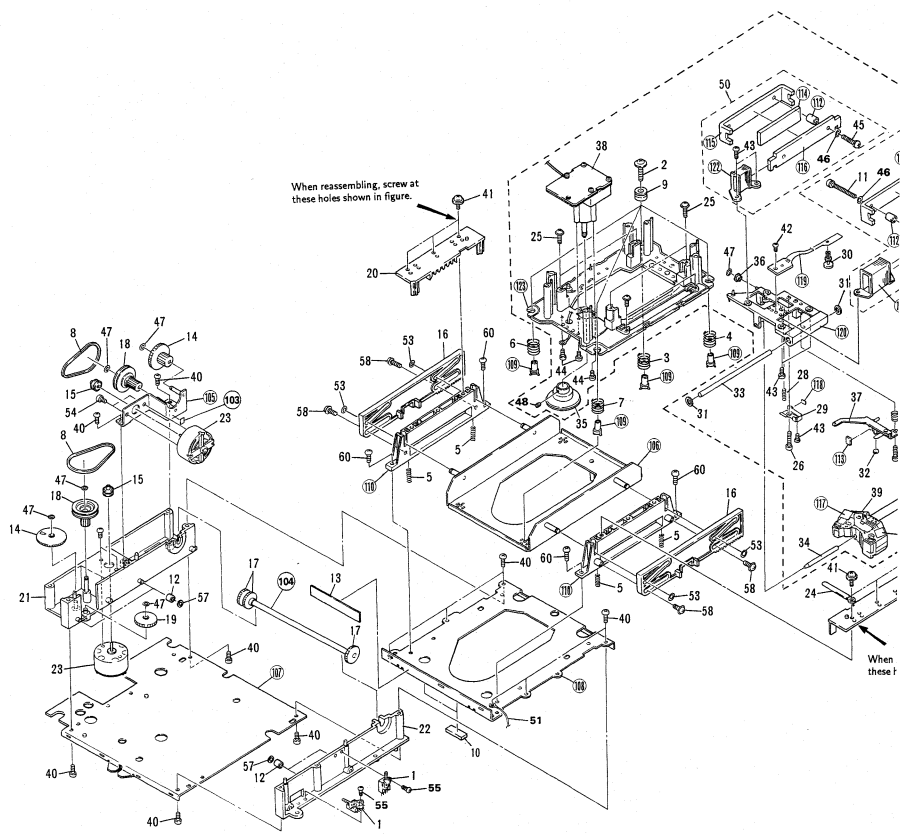

● TERMINAL VOLTAGES

Pin No.	Pin Voltage	Pin No.	Pin Voltage
1	1.6	16	-3
2	1.3	17	-5
3	0	18	0
4	2.4	19	0
5	2.8	20	0
6	-4.8	21	-4.9
7	2.2	22	0
8	2.3	23	-1
9	0	24	-2.1
10	0	25	0
11	2.6	26	2.5
12	-1.2	27	2.4
13	-0.1	28	5
14	0	29	0
15	-3.1	30	5

Pin No.	Pin Voltage	Pin No.	Pin Voltage
1	1.5	16	5
2	2.0	17	0
3	1.8	18	4.2
4	0	19	4.2
5	0	20	4.2
6	0	21	4.2
7	0	22	4.2
8	0	23	4.2
9	0	24	4.2
10	0	25	4.2
11	0.2	26	4.2
12	0.2	27	4.2
13	0.2	28	4.2
14	0.2	29	4.2
15	0.2	30	4.2

Pin No.	Pin Voltage	Pin No.	Pin Voltage
1	1.7	16	0
2	1.0	17	0
3	1.5	18	0
4	2.1	19	0
5	2.5	20	0
6	3.0	21	0
7	3.5	22	0
8	4.0	23	0
9	4.5	24	0
10	5.0	25	0
11	5.5	26	0
12	6.0	27	0
13	6.5	28	0
14	7.0	29	0
15	7.5	30	0

Pin No.	Pin Voltage	Pin No.	Pin Voltage
1	1.7	16	5
2	1.5	17	5
3	1.3	18	5
4	1.1	19	5
5	0.9	20	5
6	0.7	21	5
7	0.5	22	5
8	0.3	23	5
9	0.1	24	5
10	0	25	5
11	0	26	5
12	0	27	5
13	0	28	5
14	0	29	5
15	0	30	5

3. PACKING

- | Mark No. | Description                             | Parts No. |
|----------|---|-----------|
| 1        | Protector (F)                           | PHA1171   |
| 2        | Protector (R)                           | PHA1172   |
| 3        | CD packing case                         | PHG1676   |
| 4        | Cord with plug (pin plug)               | PDE1003   |
| 5        | Operating instruction (English, French) | PRE1149   |
| 6        | Remote control unit                     | PWW1057   |
| 7        | Battery cover                           | PZN1001   |
| 8        | Cord with plug (mini plug)              | PDE-319   |
| 9        | Mirror mat                              | VHL-087   |
| 10       | Vinyl pouch                             | Z21-013   |
| 11       | Vinyl pouch                             | Z21-038   |
| 12       | Caution label                           | PRW1246   |
| 13       | Sheet                                   | PRW1245   |
| 14       | Turntable sheet assembly                | PEA1174   |
| 15       | Turntable sheet                         | PEB1187   |
| 101      | Battery                                 |           |
| 103      | Rubber spacer                           |           |

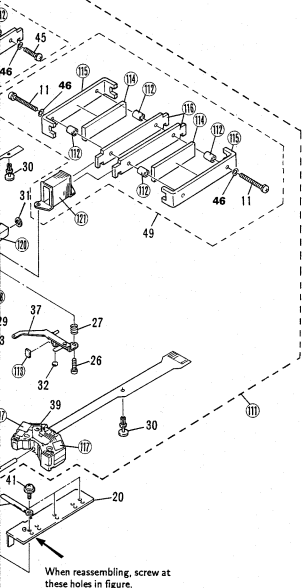
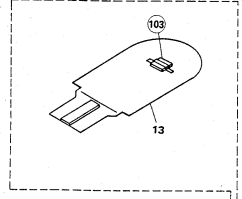

When reassembling, screw at these holes in figure.

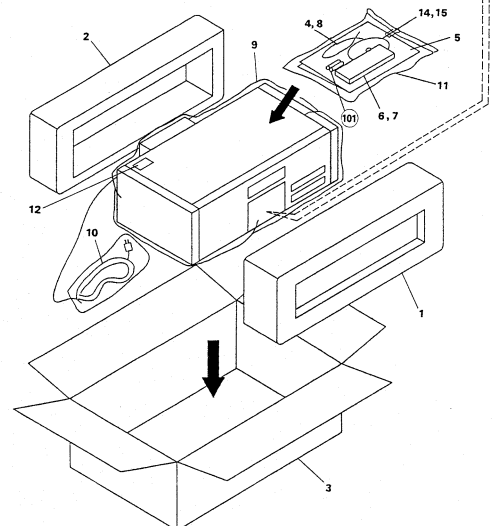

# 4. SCHEMATIC DIAGRAM AND P.C.BOARDS CONNECTION DIAGRAM

## 4.1 MAIN BOARD (PWZ 1983), PRIMARY BOARD, FUNCTION A BOARD(PWZ 2000), AND FUNCTION B BOARD ASSEMBLIES

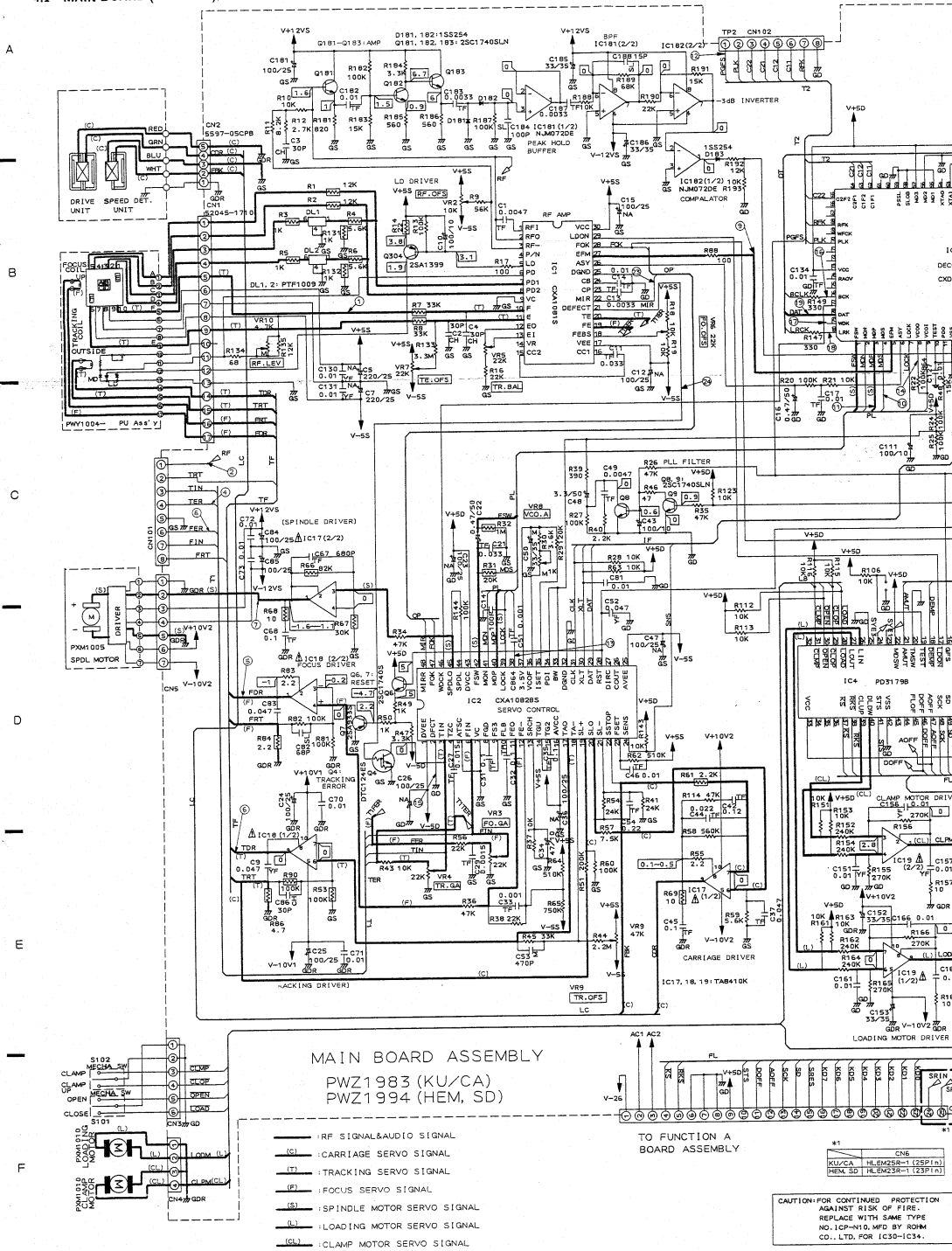

MAIN BOARD ASSEMBLY  
PWZ1983 (KU/CA)  
PWZ1994 (HEM, SD)

- RF SIGNAL&AUDIO SIGNAL
- (C) CARRIAGE SERVO SIGNAL
- (T) TRACKING SERVO SIGNAL
- (F) FOCUS SERVO SIGNAL
- (S) SPINDLE MOTOR SERVO SIGNAL
- (L) LOADING MOTOR SERVO SIGNAL
- (CL) CLAMP MOTOR SERVO SIGNAL

TO FUNCTION A BOARD ASSEMBLY

#1	CN6
KU/CA	HL6M258-1 (25P 1A)
HEM,SD	HL6M258-1 (25P 1A)

CAUTION: FOR CONTINUED PROTECTION AGAINST RISK OF FIRE, REPLACE WITH SAME TYPE NO. ICP-W/D.MFD BY ROHM CO., LTD. FOR IC30-IC34.

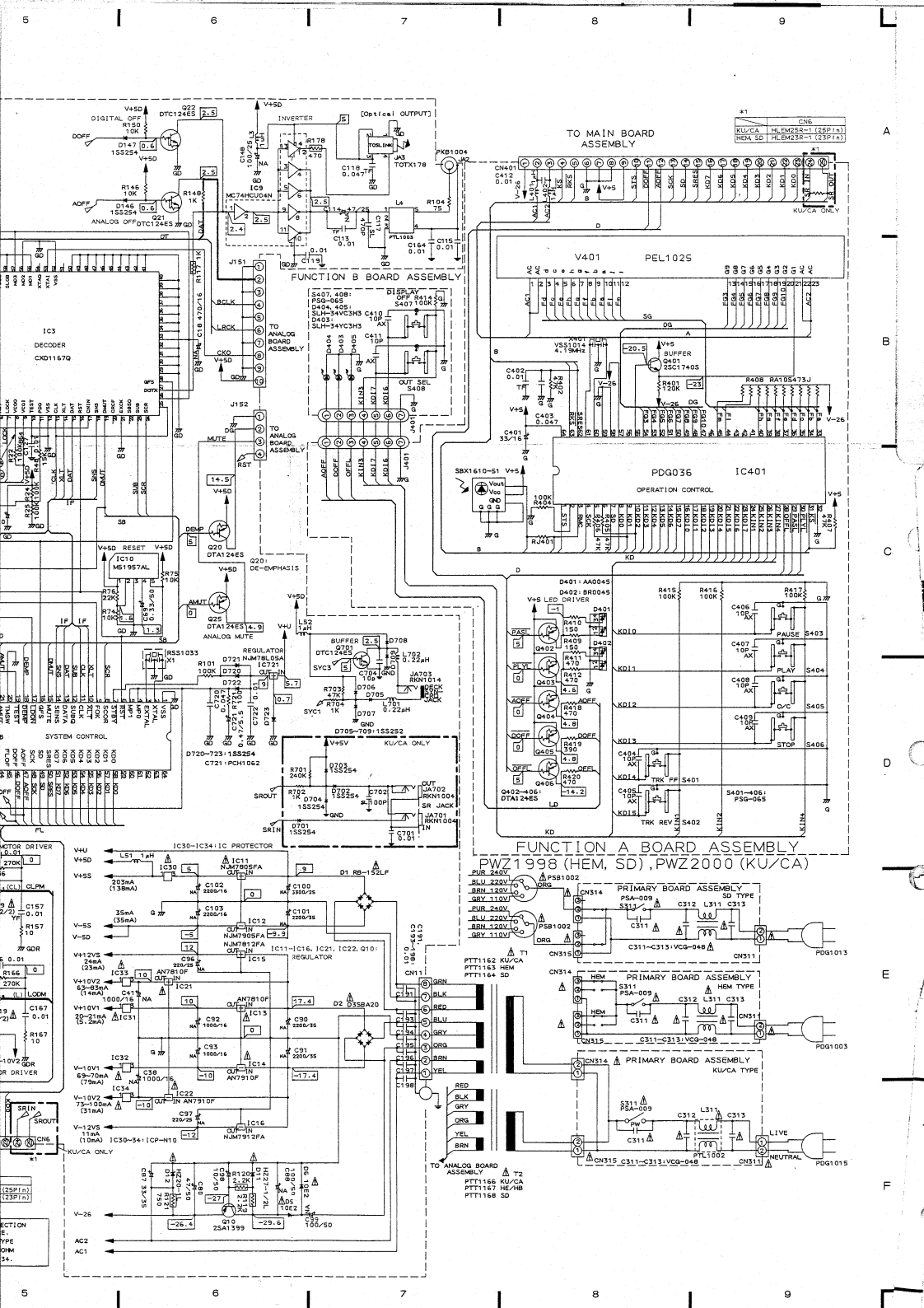

#3

Pin	Voltage	Pin	Voltage
1	0.16	-5	
2	1.17	0	
3	0.16	0	
4	2.4	1.9	0
5	0.26	0	
6	-4.8	2.1	-4.8
7	0	2.2	0
8	0	2.9	-1.1
9	0	2.4	-2.1
10	0	2.5	0
11	0	2.6	2.5
12	-1.2	2.7	2.4
13	-2.1	2.8	2.4
14	0	2.9	0
15	-3.1	3.0	0

#4

Pin	Voltage	Pin	Voltage
1	-5	5	-5
2	0	2.9	0
3	0	2.7	1.5
4	0	2.8	3
5	0	2.9	5
6	0	3.0	5
7	0	3.1	0
8	0	3.2	0
9	0	3.3	2.5
10	0	3.4	2.5
11	0	3.5	2.5
12	0	3.6	2.5
13	0	3.7	2.5
14	0	3.8	4.4
15	0	3.9	5
16	5	4.0	5
17	0	4.1	5
18	0	4.2	5
19	5	4.3	5
20	0	4.4	0
21	0	4.5	-2.5
22	0	4.6	5
23	4.1	4.7	5
24	5	4.8	0

#5

Pin	Voltage	Pin	Voltage	Pin	Voltage
1	2.5	11	0	41	0
2	2.1	12	0	42	0
3	2.5	13	0	43	0
4	2.8	14	0	44	0
5	2.4	15	0	45	0
6	2.4	16	0	46	0
7	2.7	17	0	47	0
8	2.4	18	0	48	0
9	2.4	19	1.8	49	0
10	2.5	20	1.8	50	0
11	1.8	31	0	51	2.9
12	0	32	0	52	0
13	0	33	5	53	0
14	3	34	0	54	2.2
15	3	35	0	55	2.5
16	3	36	0	56	0
17	8	37	0	57	2.9
18	3	38	0	58	0
19	8	39	0	59	0
20	3	40	0	60	3.5

#6

Pin	Voltage	Pin	Voltage	Pin	Voltage
1	0	17	0	33	4.9
2	1.5	18	0	34	5
3	2.1	19	0	35	5
4	0	20	0	36	5
5	3	21	0	37	5
6	5	22	0	38	5
7	5	23	4.6	39	5
8	0	24	0	40	5
9	0	25	0	41	5
10	3	26	0	42	5
11	3	27	0	43	5
12	3	28	0	44	5
13	5	29	0	45	5
14	5	30	0	46	5
15	5	31	0	47	5
16	5	32	0	48	5

A

B

C

D

FUNCTION A BOARD ASSEMBLY  
(PWZ2000:KU/CA TYPE)  
(PWZ1998:HEM AND SD TYPES)

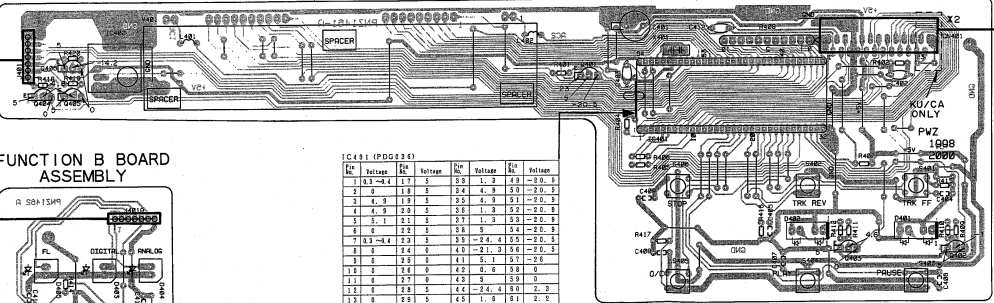

FUNCTION B BOARD ASSEMBLY

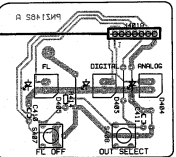

Pin	Voltage	Pin	Voltage	Pin	Voltage
1	1.83	4	1.5	13	1.3
2	0	18	5	24	4.9
3	2.5	19	5	25	4.9
4	0	20	5	26	5
5	1.1	21	5	27	1.3
6	0	22	5	28	5
7	0	23	3	29	4.15
8	0	24	0	30	4.15
9	0	25	0	31	5
10	0	26	0	32	0
11	0	27	0	33	5
12	0	28	5	34	4.8
13	0	29	5	35	1.8
14	0	30	5	36	0
15	0	31	4.1	37	0
16	1	32	5	38	-2.5

MAIN BOARD ASSEMBLY  
(PWZ1983:KU/CA TYPE)  
(PWZ1994:HEM AND SD TYPES)

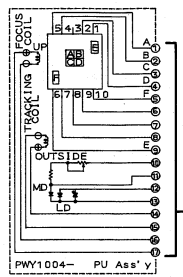
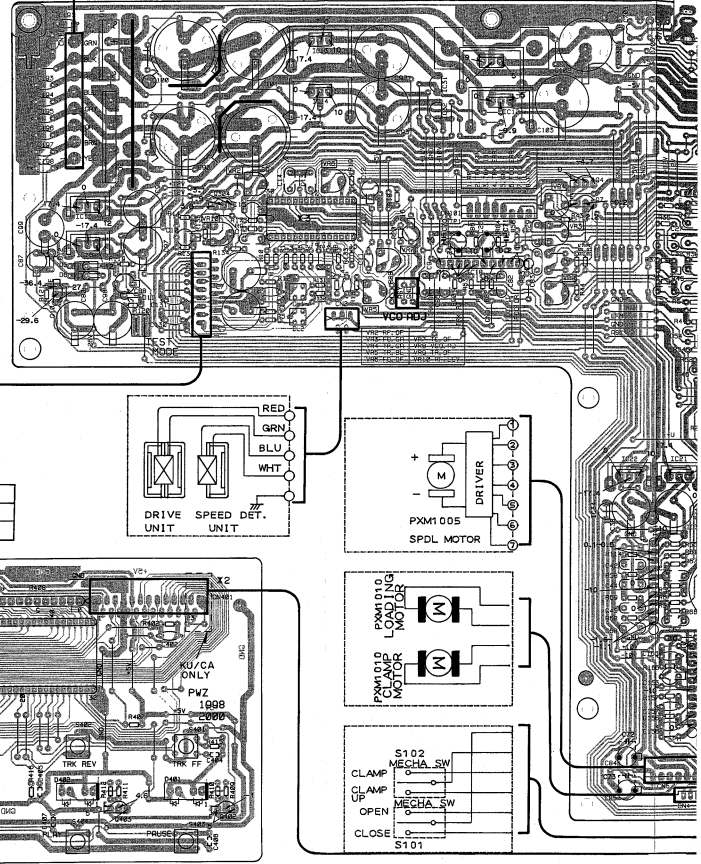

X2	Part	Value
	KU/CA	25p ins
	HEM,SD	25pins

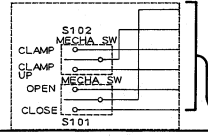
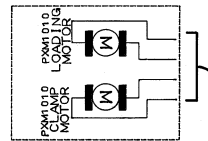
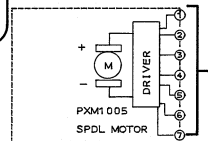
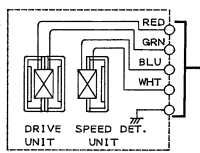

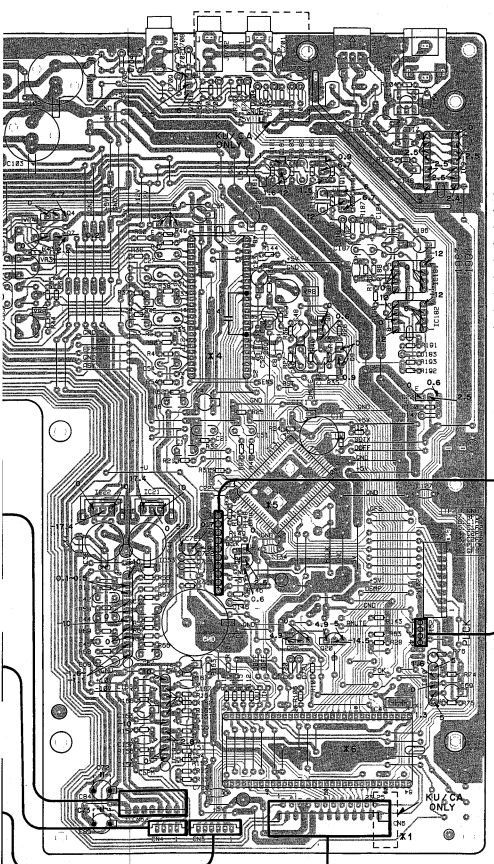

- IC13 IC30
- IC11 Q701
- IC31
- IC14
- IC32 IC12
- IC9
- Q181 Q182
- VR6
- VR2 Q183
- VR4 Q4
- VR10 Q304 Q7
- VR3 IC15 IC1
- VR7 IC16 IC181
- VR8 IC18 IC2
- VR5 IC182 IC10
- VR9 Q8

TO ANALOG BOARD ASSEMBLY

TO ANALOG BOARD ASSEMBLY

x1

Part	Value
CN6	
KU/CA	25p/ins
HEM, SD	23pins

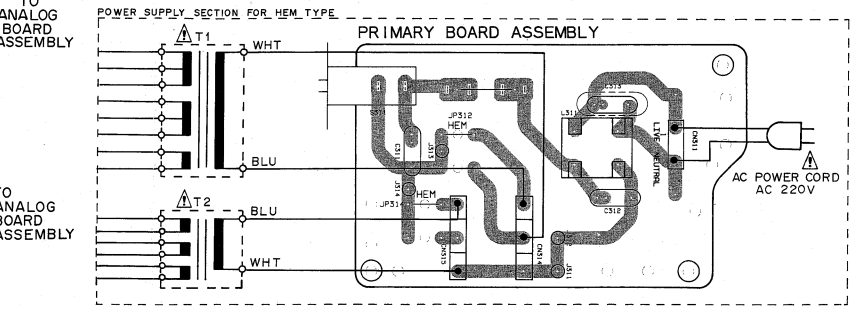
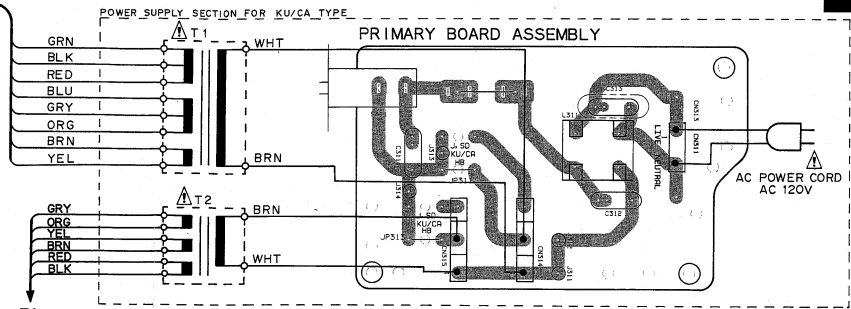

HEM 20	S&Pins
KUNCA	S&Pins
CNE	

- IC13
- IC11 Q101
- IC131
- IC14
- IC15
- IC9
- Q181 Q185
- VR8
- VR4 Q4
- VR10 Q24 Q7
- VR3 IC1
- VR18 IC1
- VR8 IC18
- VR8 IC5
- VR8 Q10 Q8
- Q55
- IC3
- IC55 IC51 IC51
- IC34 Q51
- IC33
- IC17
- Q52 Q50
- IC10
- IC19
- IC4

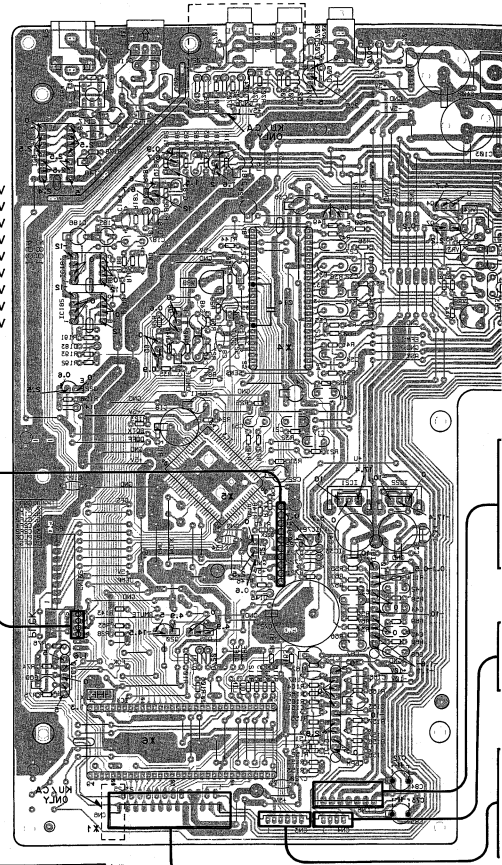

TO ANALOG BOARD ASSEMBLY

TO ANALOG BOARD ASSEMBLY

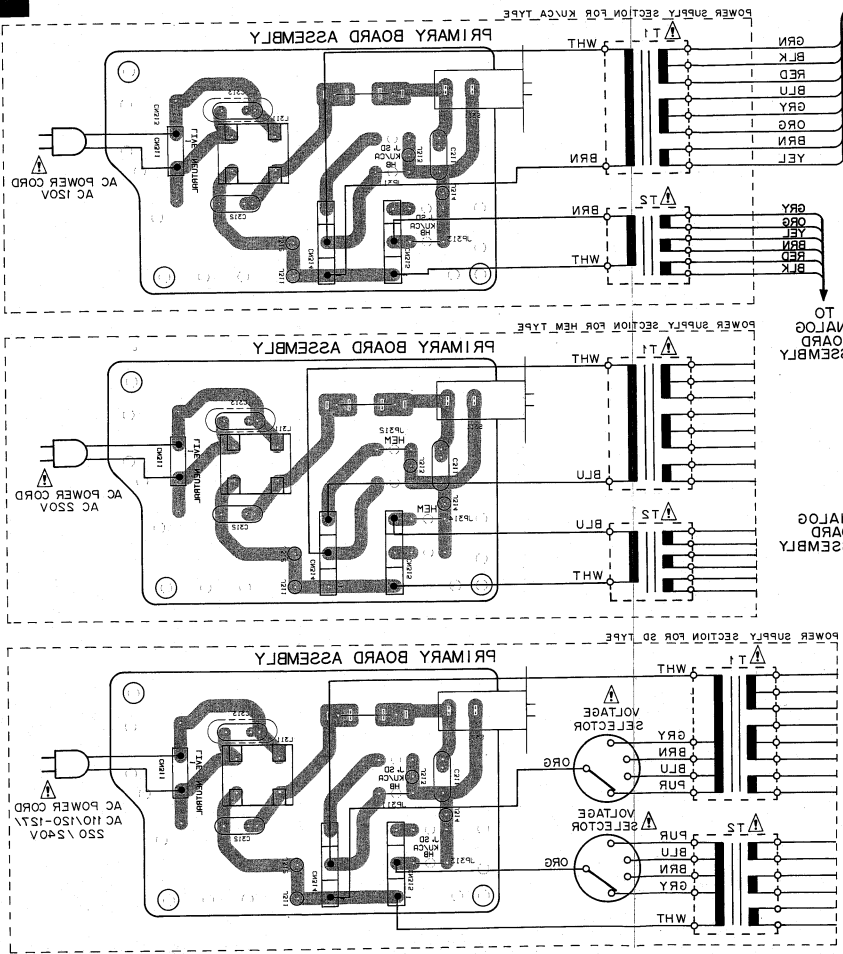

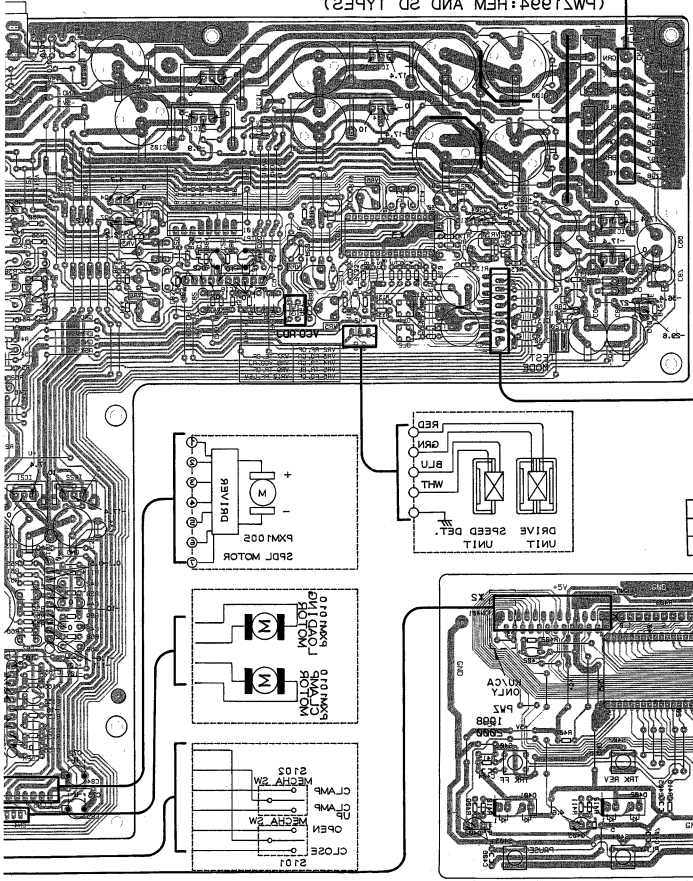

MAIN BOARD ASSEMBLY  
(PW2198:KUC CA TYPE)  
(PW2198:HEM AND 2D TYPES)

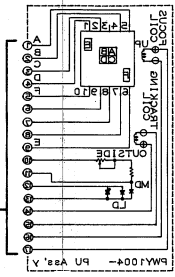

HEM_2D	S3pins
KUC CA	S3pins
CN 401	

This P.C.B. connection diagram is viewed from the foil side.

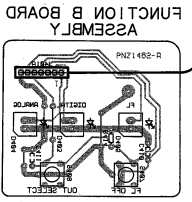

FUNCTION B BOARD ASSEMBLY  
(PW2500:KUC CA TYPE)  
(PW2500:HEM AND 2D TYPES)

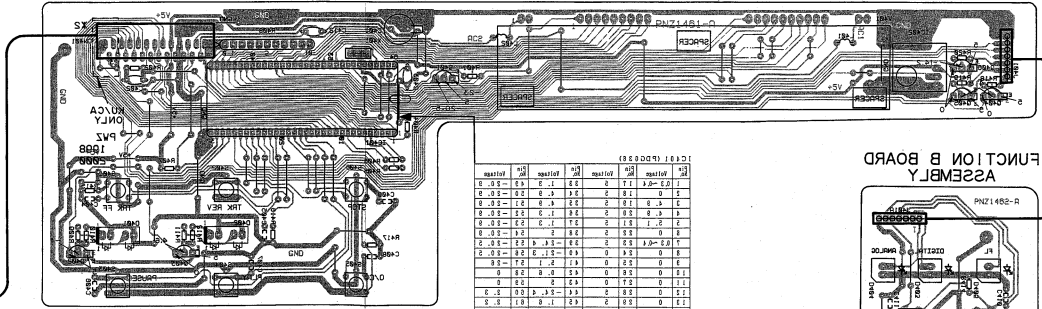

FUNCTION A BOARD ASSEMBLY  
(PW2500:KUC CA TYPE)  
(PW2500:HEM AND 2D TYPES)

IC1 (PWR100)

Pin	Function	Pin	Function
1	V5+	16	V5+
2	V5+	17	V5+
3	V5+	18	V5+
4	V5+	19	V5+
5	V5+	20	V5+
6	V5+	21	V5+
7	V5+	22	V5+
8	V5+	23	V5+
9	V5+	24	V5+
10	V5+	25	V5+
11	V5+	26	V5+
12	V5+	27	V5+
13	V5+	28	V5+
14	V5+	29	V5+
15	V5+	30	V5+

IC1 (PWR121)

Pin	Function	Pin	Function
1	V5+	16	V5+
2	V5+	17	V5+
3	V5+	18	V5+
4	V5+	19	V5+
5	V5+	20	V5+
6	V5+	21	V5+
7	V5+	22	V5+
8	V5+	23	V5+
9	V5+	24	V5+
10	V5+	25	V5+
11	V5+	26	V5+
12	V5+	27	V5+
13	V5+	28	V5+
14	V5+	29	V5+
15	V5+	30	V5+

IC1 (KUC181B)

Pin	Function	Pin	Function
1	V5+	16	V5+
2	V5+	17	V5+
3	V5+	18	V5+
4	V5+	19	V5+
5	V5+	20	V5+
6	V5+	21	V5+
7	V5+	22	V5+
8	V5+	23	V5+
9	V5+	24	V5+
10	V5+	25	V5+
11	V5+	26	V5+
12	V5+	27	V5+
13	V5+	28	V5+
14	V5+	29	V5+
15	V5+	30	V5+

IC1 (KUC181B)

Pin	Function	Pin	Function
1	V5+	16	V5+
2	V5+	17	V5+
3	V5+	18	V5+
4	V5+	19	V5+
5	V5+	20	V5+
6	V5+	21	V5+
7	V5+	22	V5+
8	V5+	23	V5+
9	V5+	24	V5+
10	V5+	25	V5+
11	V5+	26	V5+
12	V5+	27	V5+
13	V5+	28	V5+
14	V5+	29	V5+
15	V5+	30	V5+

IC1 (KUC181B)

Pin	Function	Pin	Function
1	V5+	16	V5+
2	V5+	17	V5+
3	V5+	18	V5+
4	V5+	19	V5+
5	V5+	20	V5+
6	V5+	21	V5+
7	V5+	22	V5+
8	V5+	23	V5+
9	V5+	24	V5+
10	V5+	25	V5+
11	V5+	26	V5+
12	V5+	27	V5+
13	V5+	28	V5+
14	V5+	29	V5+
15	V5+	30	V5+

1

2

3

4

5

6

7

8

9





4.2 ANALOG BOARD(PWM 1364) AND BALANCE BOARD ASSEMBLIES

ANALOG BOARD ASSEMBLY (PWM1364)

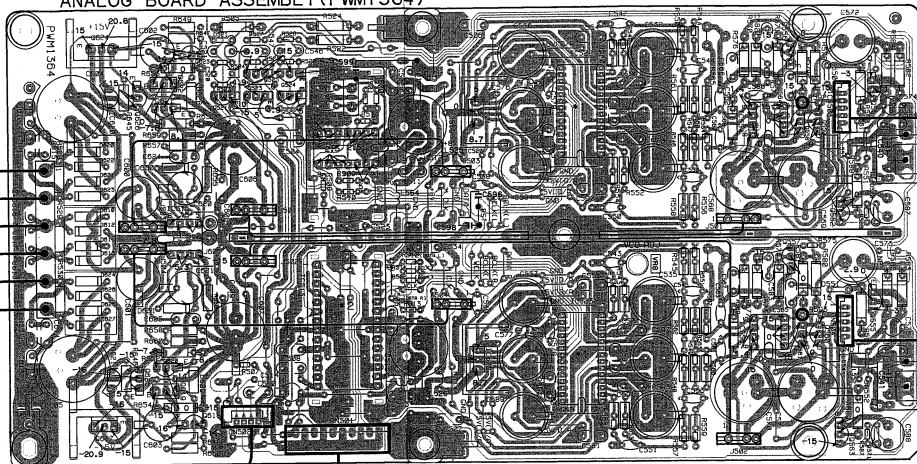

TO POWER TRANSFORMER

ORG

GRY

BLK

RED

BRN

YEL

TO MAIN BOARD ASSEMBLY

Q624 Q622 Q623 Q525 Q524 IC512 IC501 IC522 IC554 Q556 Q559 Q554  
 IC620 Q626 Q621 Q521 Q523 Q522 IC513 IC502 IC523 IC555 Q557 Q560 Q555  
 IC621 Q625 Q620 IC615 Q558 Q562  
 Q617 Q619 Q618 Q561 Q563

TO MAIN BOARD ASSEMBLY

BALANCE BOARD ASSEMBLY

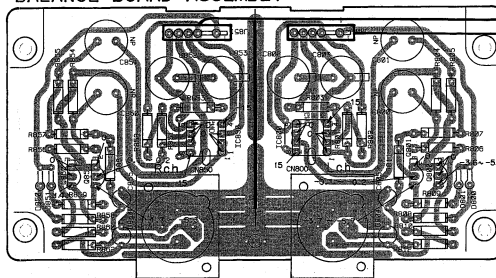

Q850 Q851 IC850 IC800 Q801 Q800

\*1

Pin	IC522	IC523	Pin	IC522	Pin	IC523
1	0	1.5	5			
2	2.6	1.6	5			
3	0	1.1	5			
4	0	1.8	0			
5	0	1.9	3.6			
6	0	1.0	2.2			
7	0	2.1	0			
8	2.5	2.2	0			
9	0	2.3	2			
10	0	2.4	0			
11	0	2.5	3.2			
12	0	2.6	2.5			
13	0	2.7	0			
14	0	2.8	5			

\*2

Pin	IC512	Pin	IC512	Pin	IC513
1	2.5	1.5	5		
2	2.4	1.6	0		
3	0	1.1	5		
4	0	1.8	0		
5	0	1.9	0		
6	0	2.0	2.4		
7	0	2.1	0		
8	0	2.2	5		
9	0	2.3	1.9		
10	0	2.4	1.6		
11	0	2.5	3.1		
12	0	2.6	2.1		
13	0	2.7	2.5		
14	0	2.8	2.5		

PCB pattern diagram	Component part symbol	Part name	PCB pattern diagram reference	Corresponding part symbol	Part name
		Capacitor	C3		Capacitor
		Resistor	R1		Resistor
		Diode	D1		Diode
		Zener diode	Z1		Zener diode
		LED	L1		LED
		Variable capacitor	VC1		Variable capacitor
		Fixed capacitor	FC1		Fixed capacitor
		Variable resistor	VR1		Variable resistor
		Resistor array	RA1		Resistor array
		Resistor	R2		Resistor
		Resistor	R3		Resistor
		Resistor	R4		Resistor
		Resistor	R5		Resistor
		Resistor	R6		Resistor
		Resistor	R7		Resistor
		Resistor	R8		Resistor
		Resistor	R9		Resistor
		Resistor	R10		Resistor
		Resistor	R11		Resistor
		Resistor	R12		Resistor
		Resistor	R13		Resistor
		Resistor	R14		Resistor
		Resistor	R15		Resistor
		Resistor	R16		Resistor
		Resistor	R17		Resistor
		Resistor	R18		Resistor
		Resistor	R19		Resistor
		Resistor	R20		Resistor
		Resistor	R21		Resistor
		Resistor	R22		Resistor
		Resistor	R23		Resistor
		Resistor	R24		Resistor
		Resistor	R25		Resistor
		Resistor	R26		Resistor
		Resistor	R27		Resistor
		Resistor	R28		Resistor
		Resistor	R29		Resistor
		Resistor	R30		Resistor
		Resistor	R31		Resistor
		Resistor	R32		Resistor
		Resistor	R33		Resistor
		Resistor	R34		Resistor
		Resistor	R35		Resistor
		Resistor	R36		Resistor
		Resistor	R37		Resistor
		Resistor	R38		Resistor
		Resistor	R39		Resistor
		Resistor	R40		Resistor
		Resistor	R41		Resistor
		Resistor	R42		Resistor
		Resistor	R43		Resistor
		Resistor	R44		Resistor
		Resistor	R45		Resistor
		Resistor	R46		Resistor
		Resistor	R47		Resistor
		Resistor	R48		Resistor
		Resistor	R49		Resistor
		Resistor	R50		Resistor
		Resistor	R51		Resistor
		Resistor	R52		Resistor
		Resistor	R53		Resistor
		Resistor	R54		Resistor
		Resistor	R55		Resistor
		Resistor	R56		Resistor
		Resistor	R57		Resistor
		Resistor	R58		Resistor
		Resistor	R59		Resistor
		Resistor	R60		Resistor
		Resistor	R61		Resistor
		Resistor	R62		Resistor
		Resistor	R63		Resistor
		Resistor	R64		Resistor
		Resistor	R65		Resistor
		Resistor	R66		Resistor
		Resistor	R67		Resistor
		Resistor	R68		Resistor
		Resistor	R69		Resistor
		Resistor	R70		Resistor
		Resistor	R71		Resistor
		Resistor	R72		Resistor
		Resistor	R73		Resistor
		Resistor	R74		Resistor
		Resistor	R75		Resistor
		Resistor	R76		Resistor
		Resistor	R77		Resistor
		Resistor	R78		Resistor
		Resistor	R79		Resistor
		Resistor	R80		Resistor
		Resistor	R81		Resistor
		Resistor	R82		Resistor
		Resistor	R83		Resistor
		Resistor	R84		Resistor
		Resistor	R85		Resistor
		Resistor	R86		Resistor
		Resistor	R87		Resistor
		Resistor	R88		Resistor
		Resistor	R89		Resistor
		Resistor	R90		Resistor
		Resistor	R91		Resistor
		Resistor	R92		Resistor
		Resistor	R93		Resistor
		Resistor	R94		Resistor
		Resistor	R95		Resistor
		Resistor	R96		Resistor
		Resistor	R97		Resistor
		Resistor	R98		Resistor
		Resistor	R99		Resistor
		Resistor	R100		Resistor

1. This PCB correction diagram is shown here for your reference only.  
 2. The area which has been reserved on the Board can be replaced with those shown with the corresponding wiring symbols based on the above table.  
 3. The resistor terminal marked with  $\ominus$  shows negative terminal.  
 4. The diode marked with  $\ominus$  shows cathode side.  
 5. The transistor terminal marked with  $\ominus$  shows emitter.

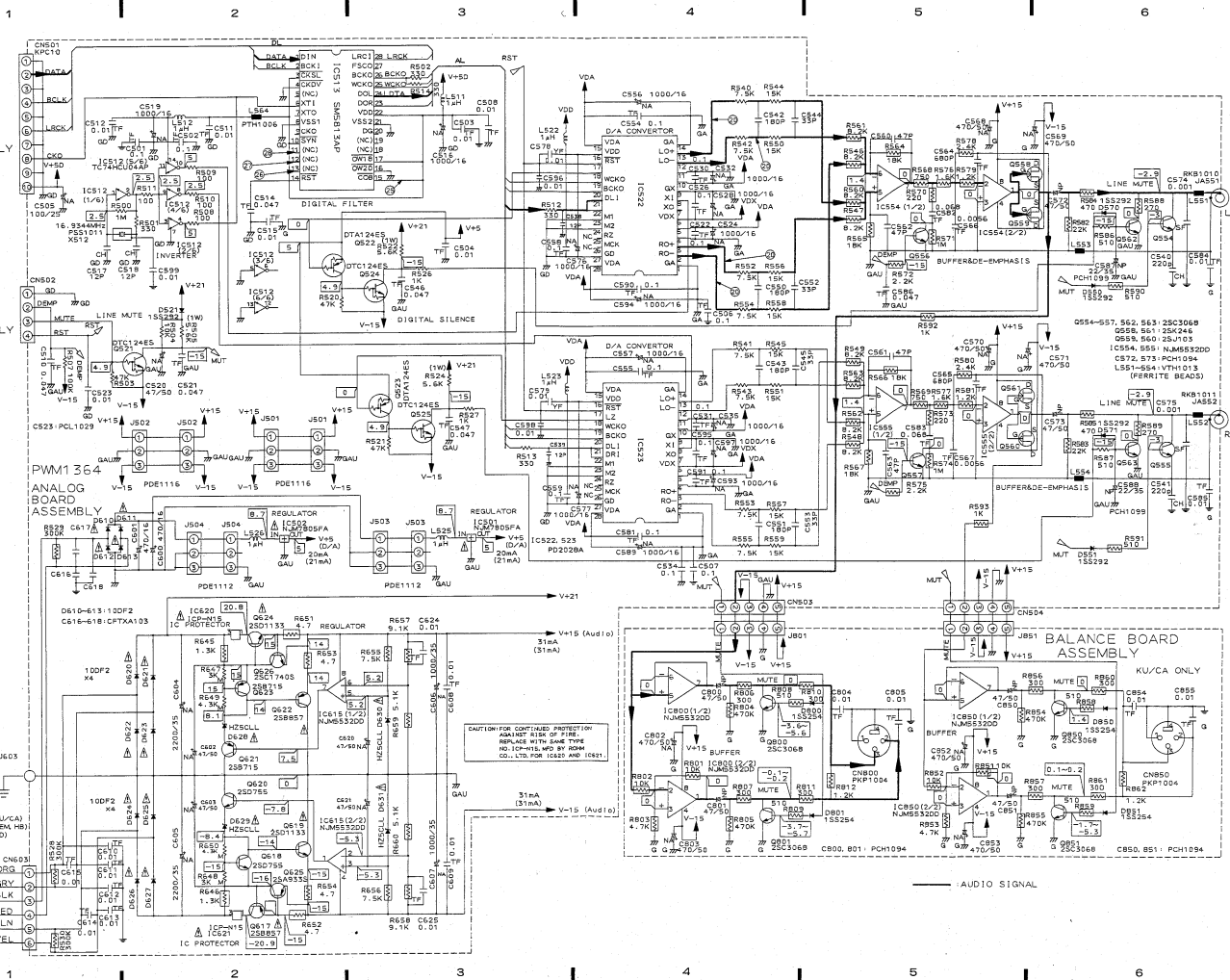

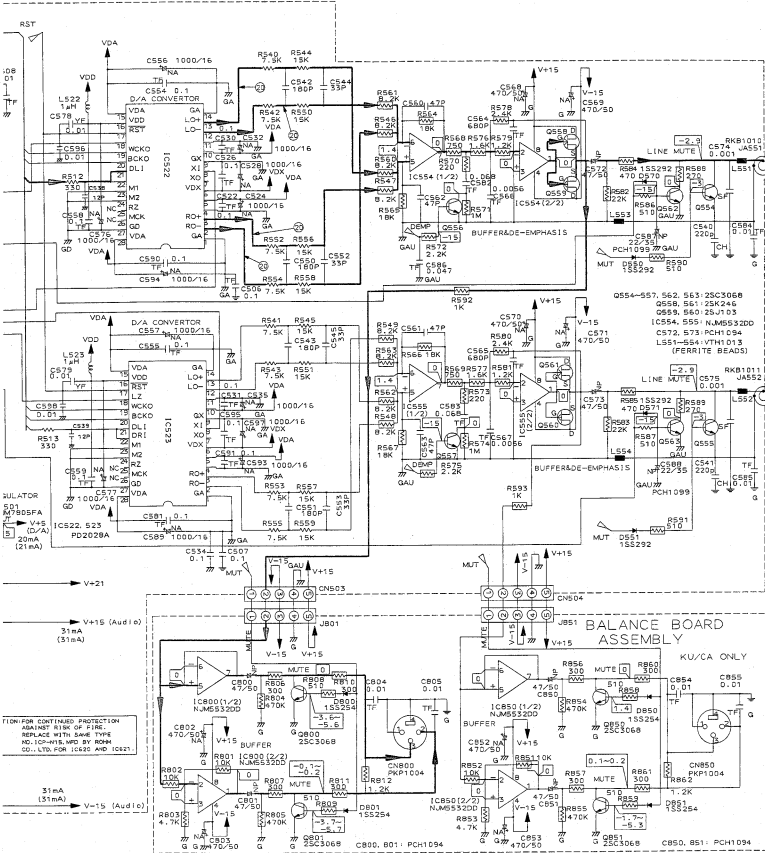

- 1. RESISTORS:**  
 Indicated in D, 1/4W, 1/8W and 1/16W. ±5% tolerance unless otherwise noted; k: kΩ, M: MΩ, (F): ±1%, (G): ±2%, (K): ±10%, (M): ±20% tolerance.
- 2. CAPACITORS:**  
 Indicated in capacity (μF)/voltage(V) unless otherwise noted; p: pF. Indication without voltage is 50 V except electrolytic capacitor.
- 3. VOLTAGE CURRENT:**  
 □: DC current (V) at play state.  
 ◻: DC current at stop state.  
 Value in ( ) is DC current at stop state.
- 4. OTHERS:**  
 ●: Signal route.  
 ⊙: Adjusting point.  
 The Δ mark found on some component parts indicates the importance of the safety factor of the part. Therefore, when replacing, be sure to use parts of identical designation.  
 ※ marked capacitors and resistors have parts numbers.

This is the basic schematic diagram, but the actual circuit may vary due to improvements in design.

- 5. SWITCHES: (The underlined indicates the switch position)**
- PRIMARY BOARD ASSEMBLY**  
**S311 POWER**

- FUNCTION A BOARD ASSEMBLY**  
**S401 TRACK SEARCH**  
**S402 PAUSE**  
**S403 PLAY**  
**S404 OPEN/CLOSE**  
**S406 STOP**
- FUNCTION B BOARD ASSEMBLY**  
**S407 DISPLAY OFF**  
**S408 OUTPUT**

FOR CONTINUED PROTECTION AGAINST FIRE HAZARD, REPLACE WITH SAME TYPE AND RATING. DO NOT OVERLOAD OR MISUSE.

31mA (31mA) V+15 (Audio In)

AUDIO SIGNAL

4.3 WAVEFORMS

NOTE: The encircled numbers denote measuring points in the schematic diagram.

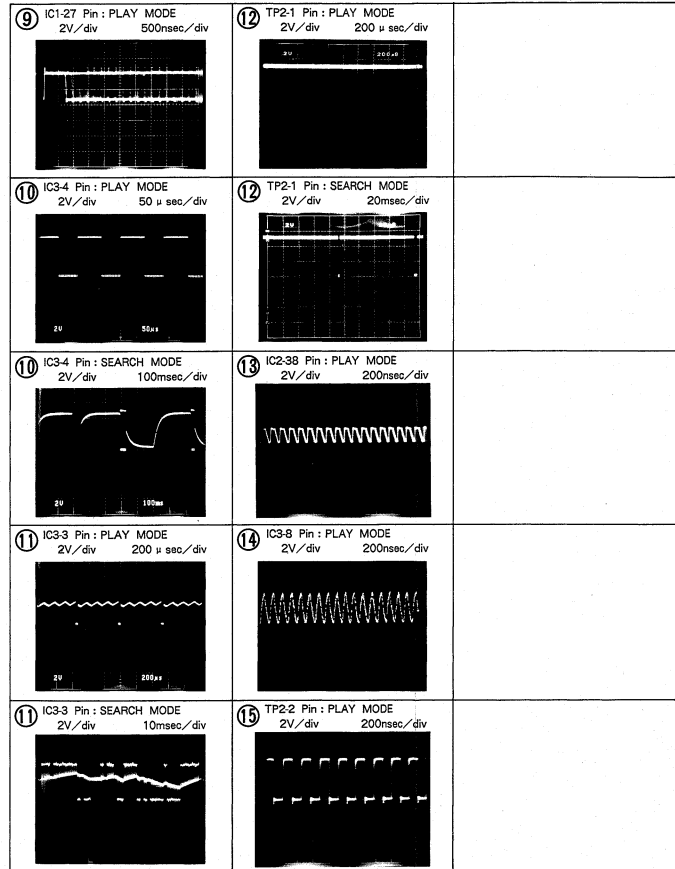
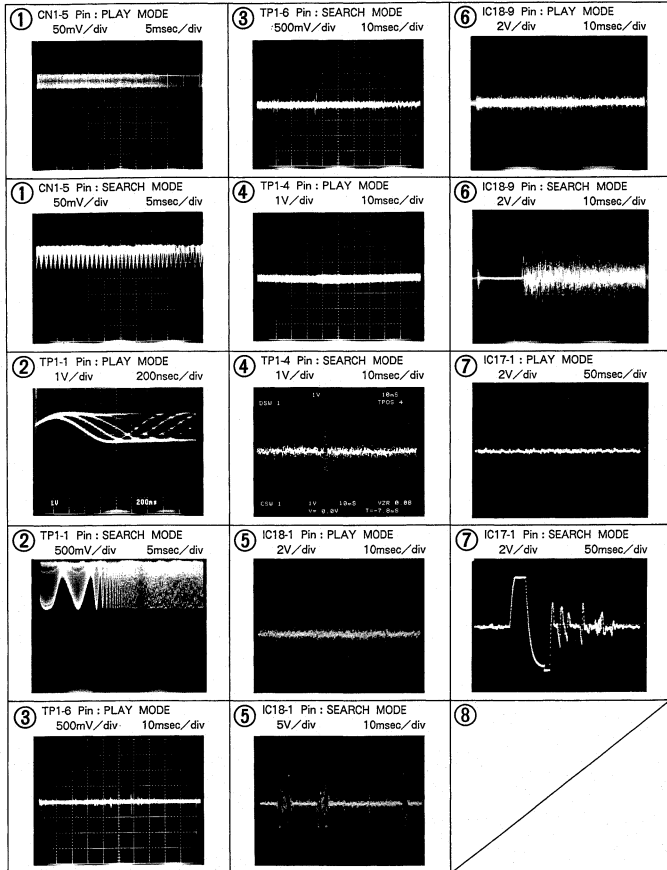

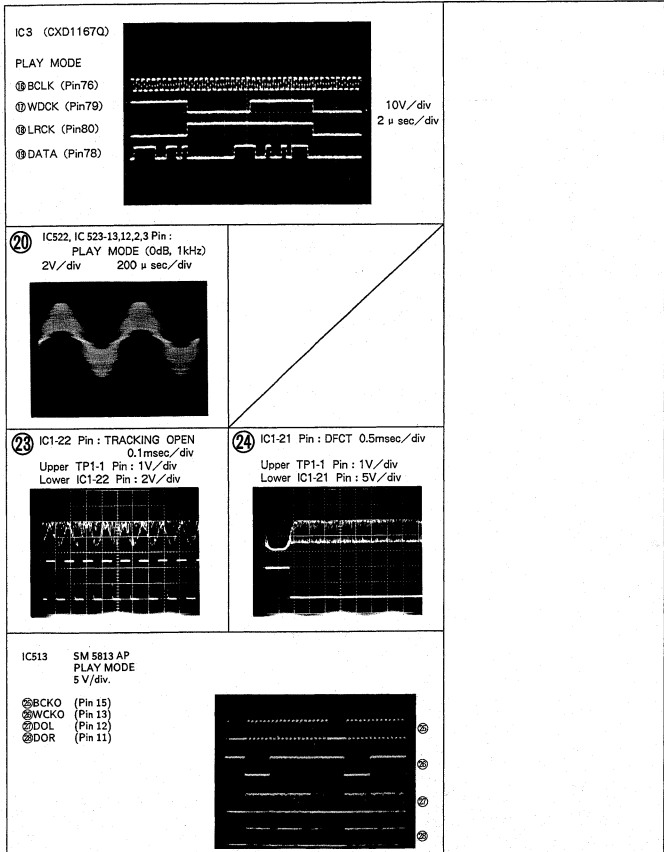

## 5. P.C.B.'s PARTS LIST

### NOTES :

- Parts without part number cannot be supplied.
- Parts marked by "●" are not always kept in stock. Their delivery time may be longer than usual or they may be unavailable.
- The  $\Delta$  mark found on some component parts indicates the importance of the safety factor of the part. Therefore, when replacing, be sure to use parts of identical designation.
- When ordering resistors, first convert resistance values into code form as shown in the following examples.

Ex.1 When there are 2 effective digits (any digit apart from 0), such as 560 ohm and 47k ohm (tolerance is shown by J = 5%, and K = 10%).

560 $\Omega$ 56 $\times 10^1$ 561 .....	RD1/APS561J
47k $\Omega$ 47 $\times 10^3$ 473 .....	RD1/APS473J
0.5 $\Omega$ 0R5 .....	RD2H0R5K
1 $\Omega$ 010 .....	RD1P010K

Ex.2 When there are 3 effective digits (such as in high precision metal film resistors).

5.62k $\Omega$ 562 $\times 10^3$ 5621 .....	RD1/4SR5621F
---	--------------

Mark	No.	Description	Parts No.	Mark	No.	Description	Parts No.
<b>●ANALOG BOARD ASSEMBLY (PWW1364)</b>				<b>COILS AND FILTERS</b>			
<b>SEMICONDUCTORS</b>				<b>CAPACITORS</b>			
	IC501, IC502	REGULATOR IC	NJM7805FA	L511, L512	AXIAL INDUCTOR	LAU010K	
	IC512	LOGIC IC	TC74HC04AP	L522, L523	AXIAL INDUCTOR	LAU010K	
	IC513	IC	SM5813AP	L526, L527	AXIAL INDUCTOR	LAU010K	
	IC522, IC523	D/A CONVERTER, IC	PD2028A	L551, L554	FERRITE BEADS	VTH1013	
	IC554, IC555	OP-AMP IC	NJM5532DD	L564		PTH1006	
	IC615	OP-AMP IC	NJM5532DD	C501, C502	AUDIO FILM CAPACITOR	CFTXA104J50	
$\Delta$	IC620, IC621	IC PROTECTOR	ICP-N15	C503, C504	AUDIO FILM CAPACITOR	CFTXA103J50	
	Q521	TRANSISTOR	DTC124ES	C505	ELECTROLYTIC CAPACIT	CENA101M25	
	Q522, Q523	TRANSISTOR	DTA124ES	C506, C507	AUDIO FILM CAPACITOR	CFTXA104J50	
	Q524, Q525	TRANSISTOR	DTC124ES	C508	AUDIO FILM CAPACITOR	CFTXA103J50	
	Q554, Q557	TRANSISTOR	2SC3068	C510	AUDIO FILM CAPACITOR	CFTXA473J50	
	Q558	TRANSISTOR	2SK246	C511, C512	AUDIO FILM CAPACITOR	CFTXA103J50	
	Q559, Q560	FET	2SJ103	C514	AUDIO FILM CAPACITOR	CFTXA473J50	
	Q561	TRANSISTOR	2SK246	C515	AUDIO FILM CAPACITOR	CFTXA103J50	
	Q562, Q563	TRANSISTOR	2SC3068	C516	ELECTROLYTIC CAPACIT	CENA102M16	
$\Delta$	Q617	TRANSISTOR	2SB857	C517, C518	CERAMIC CAPACITOR	CCCCH120J50	
	Q618	TRANSISTOR	2SD756	C519	ELECTROLYTIC CAPACIT	CENA102M16	
$\Delta$	Q619	POWER TRANSISTOR	2SD1133	C520	ELECTROLYTIC CAPACIT	CENA470M50	
	Q620	TRANSISTOR	2SD755	C521	AUDIO FILM CAPACITOR	CFTXA473J50	
$\Delta$	Q621	TRANSISTOR	2SB715	C522	AUDIO FILM CAPACITOR	CFTXA104J50	
	Q622	TRANSISTOR	2SB857	C523	CERAMIC CAPACITOR	PCL1025	
	Q623	TRANSISTOR	2SB715	C524	ELECTROLYTIC CAPACIT	CENA102M16	
$\Delta$	Q624	POWER TRANSISTOR	2SD1133	C526	AUDIO FILM CAPACITOR	CFTXA104J50	
	Q625	TRANSISTOR	2SA933S	C528	ELECTROLYTIC CAPACIT	CENA102M16	
	Q626	TRANSISTOR	2SC1740S	C530, C531	AUDIO FILM CAPACITOR	CFTXA104J50	
	D521	DIODE	1S8292	C532	ELECTROLYTIC CAPACIT	CENA102M16	
	D550, D551	DIODE	1S8292	C534	AUDIO FILM CAPACITOR	CFTXA104J50	
	D570, D571	DIODE	1S8292	C535	ELECTROLYTIC CAPACIT	CENA102M16	
$\Delta$	D610, D613	DIODE	10DF2	C538, C539	CERAMIC CAPACITOR	CCCCH120J50	
$\Delta$	D620, D627	DIODE	10DF2	C540, C541	CERAMIC CAPACITOR	CDCDCH221J50	
$\Delta$	D628, D631	ZENER DIODE	HZ5CLL	C542, C543	MICA CAPACITOR	CMA181J500	
				C544, C545	MICA CAPACITOR	CMA330J500	
				C546, C547	AUDIO FILM CAPACITOR	CFTXA473J50	
				C550, C551	MICA CAPACITOR	CMA181J500	
				C552, C553	MICA CAPACITOR	CMA330J500	

Mark No.	Description	Parts No.
C354, C555	AUDIO FILM CAPACITOR	CFTXA104J50
C556, C557	ELECTROLYTIC CAPACIT	CENA102M16
C558, C559	AUDIO FILM CAPACITOR	CFTXA104J50
C560, C563	MICA CAPACITOR	CMA4703500
C564, C565		CFTXA681J50
C566, C567		CFTXA562J50
C568, C571	ELECTROLYTIC CAPACIT	CENA471M50
C572, C573	ELECTROLYTIC CAPACIT	PCH1094
C574, C575	PL-STYRENE CAPACITOR	CQSF102J50
C576, C577	ELECTROLYTIC CAPACIT	CENA102M16
C578, C579	AUDIO FILM CAPACITOR	CFTXA103J50
C581	AUDIO FILM CAPACITOR	CFTXA104J50
C582, C583	AUDIO FILM CAPACITOR	CFTXA683J50
C584, C585	AUDIO FILM CAPACITOR	CFTXA103J50
C586	AUDIO FILM CAPACITOR	CFTXA473J50
C587, C588	ELECTR. CAPACITOR	PCH1099
C589	ELECTROLYTIC CAPACIT	CENA102M16
C590, C591	AUDIO FILM CAPACITOR	CFTXA104J50
C593, C594	ELECTROLYTIC CAPACIT	CENA102M16
C595	AUDIO FILM CAPACITOR	CFTXA104J50
C596	CERAMIC CAPACITOR	CKDYF103Z50
C597	ELECTROLYTIC CAPACIT	CENA102M16
C598	CERAMIC CAPACITOR	CKDYF103Z50
C599	AUDIO FILM CAPACITOR	CFTXA103J50
C600, C601	ELECTROLYTIC CAPACIT	CENA471M16
C602, C603	ELECTROLYTIC CAPACIT	CENA470M50
C604, C605	ELECTR. CAPACITOR	PCH1102
C606, C607	ELECTROLYTIC CAPACIT	CENA102M35
C608, C618	AUDIO FILM CAPACITOR	CFTXA103J50
C620, C621	ELECTROLYTIC CAPACIT	CENA470M50
C624, C625	AUDIO FILM CAPACITOR	CFTXA103J50

**RESISTORS**

R505, R522	METAL OXIDE RESISTOR	RS1LMF562J
R524	METAL OXIDE RESISTOR	RS1LMF562J
R528, R530	CARBON FILM RESISTOR	RDR1/4PM304J
R540, R567	CARBON FILM RESISTOR	RDR1/4PM□□□□
R568, R671	CARBON FILM RESISTOR	RDM1/2P□□□□
R573, R574	CARBON FILM RESISTOR	RDM1/2P□□□□
R576, R585	CARBON FILM RESISTOR	RDM1/2P□□□□
R588, R589	CARBON FILM RESISTOR	RDM1/2P271J
R590, R593	CARBON FILM RESISTOR	RDM1/2P□□□□
R645, R646	CARBON FILM RESISTOR	RDR1/4PM132J
R647, R650	METALFILM RESISTER	RN1/4PQ□□□□F
R651, R654	CARBON FILM RESISTOR	RDR1/2PM4R7J
R655, R680	CARBON FILM RESISTOR	RDR1/4PM□□□□
Other resistors		RDL/6PM□□□□

**OTHERS**

CN501	CONNECTOR(10P)	KPC10
JA551	1P PIN JACK(W)	RKB1010
JA552	1P PIN JACK(R)	RKB1011
X512	XTAL RES (OSC)	PSS1011
SCREW		IBZ30P100FCC

**MAIN BOARD ASSEMBLY (PWZ1983)**

**SEMICONDUCTORS**

IC1	PRE AMP IC	CXA1081S
IC2	SERVO CONTROL IC	CXA1082B5
IC3	EPM DEMODULATION IC	CXD1167Q
IC4	MICROCOMPUTER, IC	FD3179B
IC9	IC	MC74HC04N
IC10	SYSTEM RESET IC	M51957AL
IC11	REGULATOR IC	NJM7805FA
IC12	REGULATOR IC	NJM7905FA
IC13	REGULATOR IC	AN7810P
IC14	REGULATOR IC	AN7910P
IC15	REGULATOR IC	NJM7812FA
IC16	REGULATOR IC	NJM7912FA
IC17-IC19	POWER OP-AMP	TA8410K
IC21	REGULATOR IC	AN7810P
IC22	REGULATOR IC	AN7910P
IC30-IC34	IC PROTECTOR	ICP-N10
IC181, IC182	IC	NJM5072DE
IC721	REGULATOR IC	NJM78L05A
Q4	TRANSISTOR	DTC124ES
Q6	TRANSISTOR	2SC1740S
Q7	TRANSISTOR	2SA935S
Q8, Q9	TRANSISTOR	2SC1740SLN
Q10	TRANSISTOR	2SA1399
Q20	TRANSISTOR	DTA124ES
Q21, Q22	TRANSISTOR	DTA124ES
Q25	TRANSISTOR	DTA124ES
Q181-Q183	TRANSISTOR	2SC1740SLN
Q304	TRANSISTOR	2SA1399
Q701	TRANSISTOR	DTC124ES
D1		RB-152LP
D2		D35BA20
D5, D6	DIODE	10E2
D11	ZENER DIODE	HZ27-1/2L
D12	ZENER DIODE	HZ20-1L
D140, D147	DIODE	1S8254
D181-D183	DIODE	1S8254
D701-D709	DIODE	1S8254
D720-D723	DIODE	1S8254

**COILS AND FILTERS**

DL1, DL2	FILTER	PTF1009
L3	RADIAL INDUCTOR	LRA010K
L4	COIL	PTL1003
L51, L52	AXIAL INDUCTOR	LAU010K
L701, L702	AXIAL COIL	LAUR22K

**CAPACITORS**

C1	AUDIO FILM CAPACITOR	CFTXA472J50
C2-C4	CERAMIC CAPACITOR	CC0CH300J50
C5, C7	ELECTROLYTIC CAPACIT	CENA471M25
C9	CERAMIC CAPACITOR	CCGYF473Z25
C10	ELECTR. CAPACITOR	CEAS101M10





Mark No.	Description	Parts No.
	ON6 CONNECTOR	HLEM26R
	JA2 JACK	PKB1004
	JA3 OPTICAL OUTPUT JACK	TOTX178
	JA701 JACK	RKN1004
	JA702 JACK	RKN1004
	JA703 JACK	RKN1014
	X1 CERAMIC RESONATOR	RSS1033

**PRIMARY BOARD ASSEMBLY**

**SWITCH**

△ S811 SWITCH (POWER)	PSA-009
-----------------------	---------

**FILTER**

△ L311 FILTER	PTL1002
---------------	---------

**CAPACITORS**

△ C311-C313 CAPACITOR (CERAMIC)	VCG-048
---------------------------------	---------

**FUNCTION B BOARD ASSEMBLY**

**SEMICONDUCTORS**

D403 LED	SLH-34YC3H3
D404, D405 LED	SLH-34VC3H3

**SWITCHES**

S407, S408 SWITCH (DISPLAY OFF, OUTPUT)	PSG-065
--	---------

**CAPACITORS**

C410, C411 AXIAL CERAMIC C.	CCPUCH100J50
-----------------------------	--------------

**RESISTOR**

R414 CARBON FILM RESISTOR	RD1/6PM104J
---------------------------	-------------

**●FUNCTION A BOARD ASSEMBLY (PWZ2000)**

**SEMICONDUCTORS**

IC401 FL MCU	PDG036
Q401 TRANSISTOR	2SC1740S
Q402-Q406 TRANSISTOR	DTA124ES

D401 LED	AA0045
D402 LED	BR0045

**SWITCHES**

S401-S406 SWITCH (TRK FF, TRK REV, PAUSE) (PLAY, OPEN/CLOSE, STOP)	PSG-065
--	---------

**COILS**

L401 AXIAL INDUCTOR	LAU01GK
L402 AXIAL INDUCTOR	LAU01GK

Mark No.	Description	Parts No.
----------	-------------	-----------

**CAPACITORS**

C401 ELECTROLYTIC CAPACIT	CEJA330M16
C402 AUDIO FILM CAPACITOR	CFTXA103J50
C403 CERAMIC CAPACITOR	CGCYF473Z25
C404-C409 AXIAL CERAMIC C.	CCPUCH100J50
C412 CERAMIC CAPACITOR	CKCYF103Z50

**RESISTORS**

R408 RESISTOR ARRAY (47K)	RA10S473J
---------------------------	-----------

Other resistors

RD1/6PM	□□□J
---------	------

**OTHERS**

CN401 CONNECTOR	HLEM26R
V401 FL TUBE	PEL1025
X401 CERAMIC RESONATOR	VSS1014
REMOTE SENSOR	SBX1610

**BALANCE BOARD ASSEMBLY**

**SEMICONDUCTORS**

IC800, IC850 OP-AMP IC	NJM5532DD
------------------------	-----------

Q800, Q801 TRANSISTOR	2SC3068
Q850, Q851 TRANSISTOR	2SC3068

D800, D801 DIODE	1SS254
D850, D851 DIODE	1SS254

**CAPACITORS**

C800, C801 ELECTROLYTIC CAPACIT	PCH1094
C802, C803 ELECTROLYTIC CAPACIT	CENA471M35
C804, C805 AUDIO FILM CAPACITOR	CFTXA103J50
C850, C851 ELECTROLYTIC CAPACIT	PCH1094
C852, C853 ELECTROLYTIC CAPACIT	CENA471M35

C854, C855 AUDIO FILM CAPACITOR	CFTXA103J50
---------------------------------	-------------

**RESISTORS**

R801-R807 CARBON FILM RESISTOR	RDM1/2P	□□□□J
R808, R809 CARBON FILM RESISTOR	RDR1/4PM	511J
R810-R812 CARBON FILM RESISTOR	RDM1/2P	□□□□J
R851-R857 CARBON FILM RESISTOR	RDM1/2P	□□□□J
R858, R859 CARBON FILM RESISTOR	RDR1/4PM	511J

R860-R862 CARBON FILM RESISTOR	RDM1/2P	□□□□J
--------------------------------	---------	-------

## 6. ADJUSTMENTS

Perform the following adjustments in the indicated order.

### ● Adjustments

1. Tracking error offset, focus error offset and RF offset adjustment.
2. Tracking return offset adjustment.
3. Focus lock and spindle lock check.
4. Grating adjustment.
5. Tracking balance adjustment.
6. Tangential adjustment
7. Radial adjustment
8. RF level check
9. Focus gain adjustment
10. Tracking gain adjustment
11. VCO free-running frequency adjustment
12. Method of focus error check

### ● Measuring Devices

1. Dual-trace oscilloscope
2. Light power meter
3. YEDS-7 test disc
4. Focus and tracking adjustment filter
5. Loop gain adjustment band-pass filter
6. Signal generator
7. Grating driver
8. General-use tools
9. Commercial available disc (8 cm and 12 cm)
10. Hex. wrenchdriver (GGK 1002, 1.5 mm)

### ● About the test mode

#### How to activate and release the test mode

- ① To activate the test mode, turn ON the power switch with the test mode jumper short-circuited.
- ② The test mode is released by turning the power switch OFF.

The functions of the keys in the test mode are outlined in Table 1.

### ● Adjustment Volume Name

- VR2: RF offset (RF. OF)
- VR3: Focus gain (FO. GA)
- VR4: Tracking gain (TR. GA)
- VR5: Tracking balance (TR. BL)
- VR6: Focus error offset (FO. OF)
- VR7: Tracking error offset (TE. OF)
- VR8: VCO frequency counter (VCOA)
- VR9: Tracking return offset (TR. OF)
- VR10: RF level (RF.LEV)

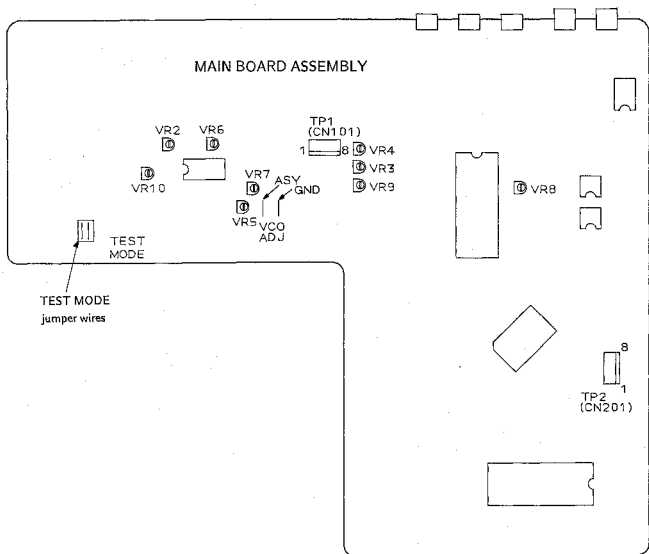
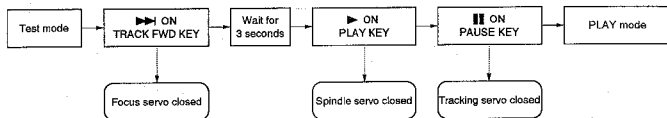

Fig.1 Adjusting point

In the test mode, closing and opening of servos is performed independently. Therefore, to set the play mode the servos have to be closed in (serial) sequence. Remember that in the test mode the play mode can't be set simply by pressing PAUSE (||) key.

For example, to set the play mode from the stop mode, press the following keys in the indicated order.



\* In the test mode, servos keep a serial sequence.

#### ● Function of Each Key in the Test Mode

Symbol	Key name	Function during test mode	Description
▶▶	TRACK FWD	Focus servo close	Lights the laser diode and sets the focus actuator UP/DOWN to close the focus servo.
▶	PLAY	Spindle servo close	After kicking the spindle motor, it closes the servo in the CLV-H mode.
	PAUSE	Tracking servo close/open	Performs a toggle operation. When pressed, the tracking servo is closed and the unit enters the play mode (the focus servo and spindle servo should be already closed). At this time the PAUSE indicator lights. If pressed again, the tracking servo opens.
	OUTPUT	Carriage reverse (inward)	Moves the carriage inwards at high (approx. 1 cm/s) speed. Since there is no safety device to stop the carriage, be sure to stop it manually in time.
	DISPLAY	Carriage forward (outward)	Moves the carriage outwards at high (approx. 1 cm/s) speed. Since there is no safety device to stop the carriage, be sure to stop it manually in time.
■	STOP	Stop	Stops all servos and returns the unit to the initial condition.
▲	OPEN/CLOSE	(Disc tray) open/close	Opens and closes the disc tray. However, the pickup does not return to the rest position when the tray is opened. It does not move either when the tray is closed.

Table 1.

Step No.	Oscilloscope setting		Test points	Adjusting points	Check items/ adjustment specifications	Adjustment procedure
	V	H				
1	<b>Tracking error offset, focus error offset and RF offset adjustment</b>					
		TP1	TP1 Pin 4 (TR, ER)	VR7 (TE, OF)	0V $\pm$ 50 mV	<ul style="list-style-type: none"> <li>● Set the test mode. (*)</li> <li>● Adjust VR7 (TE, OF: tracking error offset) so that the voltage at Pin 4 (TE: tracking error) of TP1 becomes 0V <math>\pm</math> 50 mV.</li> <li>● Adjust VR6 (FO, OF: focus error offset) so that the voltage at Pin 6 (FO, ER: focus error) of TP1 becomes 0V <math>\pm</math> 50 mV.</li> <li>● Adjust VR2 (RF, OF: RF offset) so that RF output voltage at Pin 1 of TP 1 becomes 100 mV <math>\pm</math> 50 mV.</li> </ul>
		TP1	TP1 Pin 6 (FO, ER)	VR6 (FO,OF)	0V $\pm$ 50 mV	
		TP301	TP 1 Pin 1 (RF)	VR2 (RF, OF)	100 mV $\pm$ 50 mV	
2	<b>Tracking return offset adjustment</b>					
		TP1	TP1 Pin 2 (TR, RT)	VR9 (TR, OF)	0V $\pm$ 10 mV	<ul style="list-style-type: none"> <li>● Set the test mode. (*)</li> <li>● Adjust VR9 (TR, OF: tracking return offset) so that the voltage at Pin 2 TR, RT (tracking return) of TP1 becomes 0V <math>\pm</math> 10 mV.</li> </ul>
3	<b>Focus lock and spindle lock check</b>					
	V 0.5V/div	H 100 msec /div	TP 1 Pin 1 (RF output)		RF output  Clockwise rotation	<ul style="list-style-type: none"> <li>● Load the disc.</li> <li>● Set the test mode. (*)</li> <li>● Move the pickup close to the center of the disc using DISPLAY Key. Be sure to perform this operation.</li> <li>● Observe Pin 1 RF (RF output) of TP 1 with an oscilloscope and confirm that RF signal is output after pressing TRACK FWD key (▶▶1).</li> <li>● Press PLAY key (▶) and confirm that the disc rotates clockwise at approx. normal speed (about 300 rpm around the center of the disc), without running wildly or in reverse direction.</li> </ul>

\* See page 39.

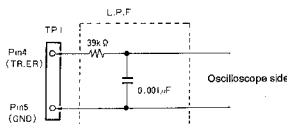
Step No.	Oscilloscope setting		Test points	Adjusting points	Check items/ adjustment specifications	Adjustment procedure
	V	H				
4-1	Grating adjustment (1) (with an 8 cm disc)					
	1V/div	5 ms/div	TP1 Pin 4 (TR. ER)	Grating	Null point	<ul style="list-style-type: none"> <li>● This adjustment can be performed with an 8 cm disc having pits over a 75 mm in diameter.</li> <li>● Load the disc. (8 cm)</li> <li>● Set the test mode. (†)</li> <li>● Press TRACK FWD (▶▶) and PLAY (▶) keys in that order to close the focus and spindle servos (the tracking servo is open state.)</li> <li>● Press DISPLAY key and move the pickup to the outer track of the 8 cm disc. When moving the pickup, it is possible to insert a slotted screwdriver in the grating adjustment plate slot from above the unit. (Fig. 3.)</li> <li>● Observe the waveform at Pin 4 TR. ER (tracking error) of TP1 with an oscilloscope and at this time, insert cut off 4 kHz low-pass filter (Fig. 2).</li> <li>● Insert the tracking driver in the adjustment slot and turn it so as to find out the null point (Photo-1).</li> </ul>
	 <p style="text-align: center;">Fig. 2.</p>					

\* See page 39.

Step No.	Oscilloscope setting		Test points	Adjusting points	Check items/ adjustment specifications	Adjustment procedure
	V	H				
4-2	<b>Grating adjustment (2) (with an 12 cm disc playing more than 60 minutes)</b>					
	1V/div	5 ms/div	TP1 Pin 4 (TR. ER)	Grating	Null point	<ul style="list-style-type: none"> <li>● Load the disc (playing more than 60 minutes).</li> <li>● Set the test mode. (*)</li> <li>● Press TRACK FWD (▶▶) and PLAY (▶) keys in that order to close the focus and spindle servos (the tracking servo is open state).</li> <li>● Press DISPLAY key and move the pickup to the outer track of the disc. When moving the pickup, it is possible to insert a slotted screwdriver in the grating adjustment plate slot from above the unit. (Fig. 3.)</li> <li>● Observe the waveform at Pin 4 TR. ER (tracking error) of TP1 with an oscilloscope and at this time, insert cut off 4 kHz low-pass filter. (Fig. 2.)</li> <li>● Insert the tracking driver in the adjustment slot and turn it so as to find out the null point (Photo-1).</li> </ul>
				Grating	Maximum amplitude	<ul style="list-style-type: none"> <li>● Turn the grating driver slowly clockwise from the null point and set to at the first point where the waveform amplitude (tracking error signal) is maximum. (See photo-2)</li> </ul>

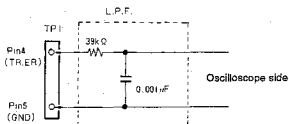

Fig. 2.

\* See page 39.



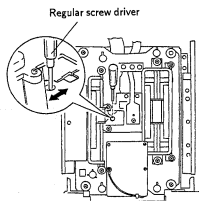

Fig. 3. Grating Adjustment

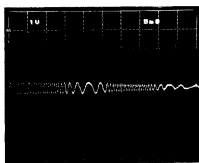

Photo-1 Null point

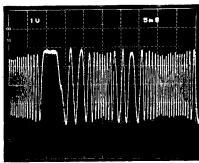

Photo-2 Maximum amplitude

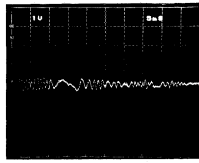
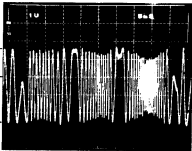
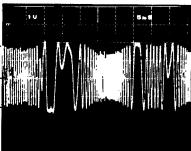

Photo-3 Out of null point

Step No.	Oscilloscope setting		Test points	Adjusting points	Check items/ adjustment specifications	Adjustment procedure
	V	H				
5	<b>Tracking balance adjustment</b>					
	0.5V/div	5 msec/div	TP1 Pin 4 (TR. ER)	VR5 (TR. BL)		<ul style="list-style-type: none"> <li>● Load the disc.</li> <li>● Set the test mode. (*)</li> <li>● Press DISPLAY key and move carriage close to the center track of the disc.</li> <li>● Press TRACK FWD (▶▶) and PLAY (▶) keys in that order to turn the disc.</li> <li>● Observe Pin 4 TR. ER (tracking error) of TP1 with an oscilloscope. And adjust VR5 TR. BL (tracking balance) so as to remove DC elements from the tracking error waveform.</li> </ul>
			A=B			
	Photo-6		Photo-7			

\* See page 39.

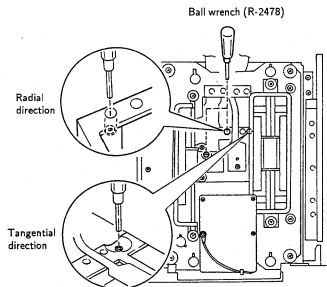

Fig. 4. Tangential Adjustment

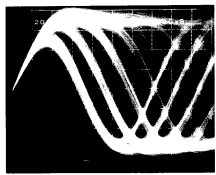

Photo-8

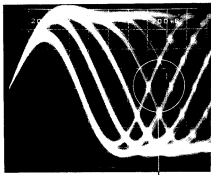

Photo-9

Part to be observed

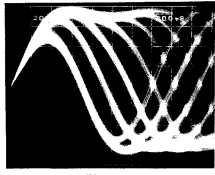
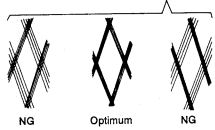
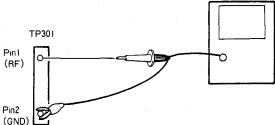

Photo-10



Step No.	Oscilloscope setting		Test points	Adjusting points	Check items/ adjustment specifications	Adjustment procedure
	V	H				
6	<b>Tangential adjustment</b>					
			TP 1 Pin 1 (RF output)	Tangential adjustment screw	Eye pattern optimum point	<ul style="list-style-type: none"> <li>● Load the disc.</li> <li>● Set the test mode. (*)</li> <li>● Press DISPLAY key and move the pickup to the center track of the disc (set it to such a location that the tangential screw can be seen from above the servo mechanism. (See fig. 4.)</li> <li>● Press TRACK FWD (▶▶), PLAY (▶) and PAUSE (■) keys in that order to close all servos. (Pause indicator lights.)</li> <li>● Observe Pin 1 RF (RF output) of TP 1 with an oscilloscope and adjust the tangential screw so that the eye pattern becomes clear. (Fig. 4.)</li> <li>● The adjustment point is located around the middle location between the point where the eye pattern becomes blurred when turning the tangential screw clockwise and the point where the eye pattern becomes blurred when turning the adjustment screw counterclockwise.</li> </ul> <p>Observe the overall clearness of the waveform and one of the diamond shapes in the eye pattern (photo-9). Optimum adjustment is attained at the point where diamond shape lines are relatively thin.</p>
						 <p style="text-align: center;">Fig. 5</p>

\* See page 39.

Step No.	Oscilloscope setting		Test points	Adjusting points	Check items/ adjustment specifications	Adjustment procedure
	V	H				
7	Radial adjustment					<ul style="list-style-type: none"> <li>● Load the disc.</li> <li>● Set the test mode. (*)</li> <li>● Press DISPLAY key and move the pickup to the center track of the disc (set it to such a location that the tangential screw can be seen from above the servo mechanism. (See fig. 4.)</li> <li>● Press TRACK FWD (▶▶), PLAY (▶) and PAUSE (■) keys in that order to close all servos. (Pause indicator lights.)</li> <li>● Observe Pin 1 RF (RF output) of TP 1 with an oscilloscope and adjust the tangential screw so that the eye pattern becomes clear. (Fig. 4.)</li> <li>● The adjustment point is located around the middle location between the point where the eye pattern becomes blurred when turning the tangential screw clockwise and the point where the eye pattern becomes blurred when turning the adjustment screw counterclockwise.</li> </ul> <p>Observe the overall clearness of the waveform and one of the diamond shapes in the eye pattern (photo-9). Optimum adjustment is attained at the point where diamond shape lines are relatively thin.</p> <ul style="list-style-type: none"> <li>● Perform the tangential and radial adjustments alternately two or more times.</li> </ul>
			TP 1 Pin 1 (RF output)	Radial adjustment screw	Eye pattern optimum point	 <p>The diagram shows a test point labeled TP301. It consists of a vertical strip with two pins. The top pin is labeled Pin1 (RF) and the bottom pin is labeled Pin2 (GND). A probe is connected to Pin1, and another probe is connected to Pin2. The probes are connected to an oscilloscope, which is represented by a rectangular box with a screen on the right.</p>

Fig. 5

\* See page 39.

Step No.	Oscilloscope setting		Test points	Adjusting points	Check items/ adjustment specifications	Adjustment procedure
	V	H				
8	<b>RF level check</b>					
			TP 1 Pin 1 (RF)	Check	1.5V $\begin{smallmatrix} +0.2V \\ -0V \end{smallmatrix}$	<ul style="list-style-type: none"> <li>● Set the test mode. (*)</li> <li>● Connect the probe of the oscilloscope to Pin 1 RF (RF output) of TP 1 .</li> <li>● Play back the disc, measure the RF waveform p-p voltage and confirm that it becomes 1.5V <math>\begin{smallmatrix} +0.2V \\ -0V \end{smallmatrix}</math> .</li> <li>● Adjust VR 10 if the voltage does not become 1.5V <math>\begin{smallmatrix} +0.2V \\ -0V \end{smallmatrix}</math> .</li> </ul>
			TP 1 Pin 1 (RF)	VR 10	1.5V $\begin{smallmatrix} +0.2V \\ -0V \end{smallmatrix}$	

\* See page 39.

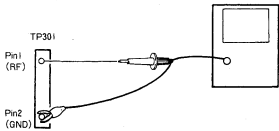
Step No.	Oscilloscope setting		Test points	Adjusting points	Check items/ adjustment specifications	Adjustment procedure
	V	H				
9	<b>Focus gain adjustment</b>					
	CH1 (X) , CH2 (Y) 20 mV/div, 5 mV/div (probe 10:1)		X axis: TP1 Pin 5 (FO. IN) Y axis: TP1 Pin 6 (FO. ER)	VR3 (FO. GA)	Phase difference 90°	<ul style="list-style-type: none"> <li>● With the power off, connect the oscilloscope and the oscillator as shown in Fig. 6.</li> <li>● Set the normal playback mode.</li> <li>● Turn the oscillators power on and set it to output a 1.2 kHz, 1 Vp-p signal.</li> </ul> <p>Note: (Some oscillators output DC when turned ON. In that case, connect the oscillator after turning it on.)</p> <ul style="list-style-type: none"> <li>● Adjust VR3 FO. GA (focus gain) so that the resurge waveform on an oscilloscope becomes a horizontal circle (phase difference 90°).</li> </ul>
						Fig. 6.
High gain Photo-11		Optimum gain Photo-12			Low gain Photo-13	

Step No.	Oscilloscope setting		Test points	Adjusting points	Check items/ adjustment specifications	Adjustment procedure
	V	H				
10	<b>Tracking gain adjustment</b>					
	CH1 (X), CH2 (Y) 50 mV/div, 5 mV/div (Probe 10:1)		X axis: TP1 Pin 3 (TR. IN) Y axis: TP1 Pin 2 (TR. ER)	VR4 (TR. GA)	Phase difference 90°	<ul style="list-style-type: none"> <li>● With the power off, connect the oscilloscope and the oscillator as shown in Fig. 7.</li> <li>● Set the normal playback mode.</li> <li>● Turn the oscillators power on and set it to output a 1 kHz, 2 Vp-p signal.</li> </ul> <p><b>Note:</b> (Some oscillators output DC when turned on. In that case, connect the oscillator after turning it on.)</p> <ul style="list-style-type: none"> <li>● Adjust VR4 TR. GA (tracking gain) so that the resurge waveform on an oscilloscope becomes a horizontal circle (phase difference 90°).</li> </ul>
	<p>Fig. 7.</p>					
	<p>High gain Photo-14</p>		<p>Optimum gain Photo-15</p>		<p>Low gain Photo-16</p>	
11	<b>VCO free-running frequency adjustment</b>					
			TP 2 Pin 2		Frequency 4.275 MHz ± 0.025 MHz	<ul style="list-style-type: none"> <li>● Set the test mode. (*)</li> <li>● Short the ASY and GND jumpers by using a slotted screw driver or similar.</li> <li>● Connect the frequency counter (10 MHz range) to Pin 2 of TP 2.</li> <li>● Adjust VR8 (VCO. A) so that the frequency counter reads 4.275 MHz ± 0.025 MHz.</li> </ul> <p><b>Note:</b> Adjust with the stop mode.</p>

\* See page 39.

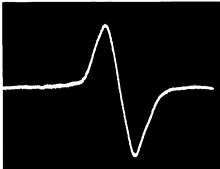

Step No.	Oscilloscope setting		Test points	Adjusting points	Check items/ adjustment specifications	Adjustment procedure
	V	H				
12	<b>Focus error check</b>					
	1V/div	2 ms/div	TP1 Pin 6 (FO, ER)	Check	Waveform	<ul style="list-style-type: none"> <li>● Set the test mode. (*)</li> <li>● Connect Pin 7 FO, IN (focus in) of TP1 to GND.</li> <li>● Press TRACK FWD key and check the waveform on Pin 6 FO, ER (focus error) of TP1 with the oscilloscope.</li> </ul>
						
Focus error Photo-17						

\* See page 39.

## 6. RÉGLAGES

Effectuer les réglages suivants dans l'ordre indiqué.

### ● Réglages

- Réglage du décalage d'erreur d'alignement, du décalage d'erreur de mise au point et du décalage RF (fréquence radio).
- Réglage du décalage de retour d'alignement.
- Contrôle du verrouillage de mise au point et du verrouillage d'axe.
- Réglage du filtre.
- Réglage de l'équilibre d'alignement.
- Réglage tangentiel.
- Réglage radial.
- Contrôle du niveau RF (fréquence radio)
- Réglage du gain de mise au point
- Réglage du gain d'alignement
- Réglage de la fréquence de relaxation du VCO (oscillateur à fréquence réglée par variation de tension)
- Méthode de contrôle d'erreur de mise au point

### ● Appareils de Mesure

- Oscilloscope à double trace
- Indicateur de puissance lumineuse
- Disc d'essai YEDS-7
- Filtre de réglage de mise au point et d'alignement
- Filtre passe-bande de réglage de gain de boucle
- Générateur de signal
- Excitateur de filtre
- Outils à usage général
- Disc disponible dans le commerce (8 cm et 12 cm)
- Clé hex. (GGK 1002, 1,5 mm)

### ● Apropos du mode d'essai

#### Mise en/hors service du mode d'essai

- Pour activer le mode d'essai, mettre l'interrupteur d'alimentation sous tension en court-circuitant le cavalier de mode d'essai.
- Le mode d'essai est annulé en ramenant l'interrupteur d'alimentation sur OFF.

Les fonctions des touches en mode d'essai sont décrites au

Tableau 1.

### ● Nom des Résistances Variables de Réglage

- VR2: Décalage RF (RF. OF)  
 VR3: Gain de mise au point (FO. GA)  
 VR4: Gain d'alignement (TR. GA)  
 VR5: Equilibre d'alignement (TR. BL)  
 VR6: Décalage d'erreur de mise au point (FO. OF)  
 VR7: Décalage d'erreur d'alignement (TE. OF)  
 VR8: Compte de fréquence VCO (VCOA)  
 VR9: Décalage de retour d'alignement (TR. OF)  
 VR 10: Niveau RF (RF.LEV)

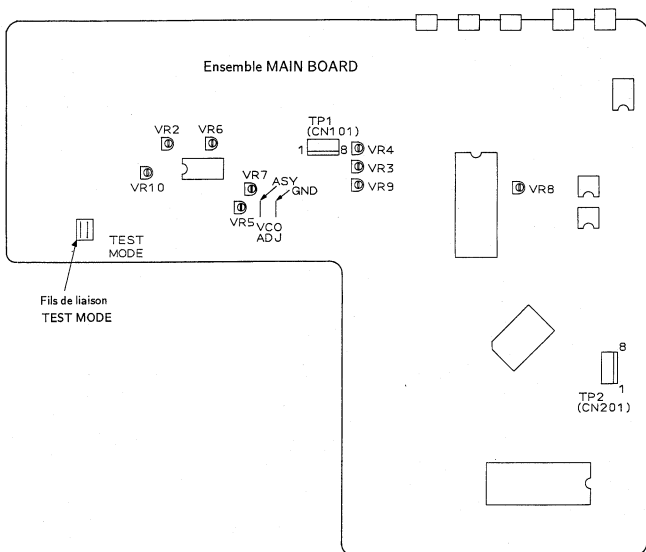
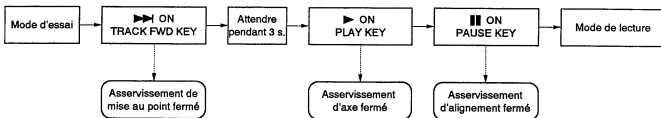

Fig.1 Points de réglage

Dans le mode d'essai, l'ouverture et la fermeture des circuits d'asservissement sont effectuées indépendamment. Par conséquent, pour régler le mode de lecture, les asservissements doivent être fermés l'un après l'autre (en série). Ne pas oublier que, dans le mode d'essai, le mode de lecture ne peut pas être réglé simplement en appuyant sur la touche PAUSE (||).

Par exemple, pour régler le mode de lecture à partir du mode d'arrêt, appuyer sur les touches suivantes dans l'ordre indiqué.



\* Dans le mode d'essai, les asservissements restent en séquence sérielle.

● Fonction de Chaque Touche dans le Mode D'essai

Symbole	Touche	Fonction en mode d'essai	Explication
▶▶	TRACK FWD	Fermeture asservissement de mise au point	Fait s'allumer la diode laser et déplace le dispositif de commande de mise au point dans le sens vertical pour fermer l'asservissement de mise au point.
▶	PLAY	Fermeture asservissement d'axe	Après le démarrage du moteur d'axe, ferme l'asservissement dans le mode CLV-H.
	PAUSE	Fermeture/ouverture asservissement d'alignement	Exécute une opération de bascule. Quand elle est enfoncée, l'asservissement d'alignement est fermé et l'appareil passe dans le mode de lecture (les asservissements de mise au point et d'axe doivent déjà être fermés). A ce moment-là le témoin de PAUSE s'allume. Si elle est de nouveau enfoncée, l'asservissement d'alignement s'ouvre.
	OUTPUT	Retour du chariot (vers l'intérieur)	Déplace le chariot vers l'intérieur à grande vitesse (approx. 1 cm/s.). Comme il n'y a pas de dispositif de sécurité pour arrêter le chariot, il faut donc l'arrêter manuellement à temps.
	DISPLAY	Avance du chariot (vers l'extérieur)	Déplace le chariot vers l'extérieur à grande vitesse (approx. 1 cm/s.). Comme il n'y a pas de dispositif de sécurité pour arrêter le chariot, il faut donc l'arrêter manuellement à temps.
■	STOP	Arrêt	Arrête tous les asservissements et ramène l'appareil à sa condition initiale.
▲	OPEN/CLOSE	Ouverture/fermeture du plateau de disc	Ouvre et ferme le plateau de disc. Le capteur ne revient cependant pas à la position d'arrêt quand le plateau est ouvert. Il ne se déplace pas non plus quand le plateau est fermé.

Tableau 1.

Etape No.	Réglage de l'oscilloscope		Points d'essai	Points de réglage	Éléments contrôlés/spécifications de réglage	Procédure de réglage
	V	H				
<b>1</b>	<b>Réglage du décalage d'erreur d'alignement, du décalage d'erreur de mise au point et du décalage RF (fréquence radio)</b>					
		TP1	TP1 Pin 4 (TR. ER)	VR7 (TE. OF)	0V ± 50 mV	<ul style="list-style-type: none"> <li>● Régler le mode d'essai. (*)</li> <li>● Ajuster VR7 (TE. OF: décalage d'erreur d'alignement) afin que la tension à la broche 4 (TE: erreur d'alignement) de TP1 devienne 0V ± 50 mV.</li> <li>● Ajuster VR6 (FO. OF: décalage d'erreur de mise au point) afin que la tension à la broche 6 (FO. ER: erreur de mise au point) de TP1 devienne 0V ± 50 mV.</li> <li>● Ajuster VR2 (RF. OF: décalage RF) afin que la tension à la broche 1 de TP1 devienne 100 mV ± 50 mV.</li> </ul>
		TP1	TP1 Pin 6 (FO. ER)	VR6 (FO. OF)	0V ± 50 mV	
		TP301	TP1 Pin 1 (RF)	VR2 (RF. OF)	100 mV ± 50 mV	
<b>2</b>	<b>Réglage du décalage de retour d'alignement</b>					
		TP1	TP1 Pin 2 (TR. RT)	VR9 (TR. OF)	0V ± 10 mV	<ul style="list-style-type: none"> <li>● Régler le mode d'essai. (*)</li> <li>● Ajuster VR9 (TR. OF: décalage de retour d'alignement) afin que la tension à la broche 2 (TR. RT: retour d'alignement) de TP1 devienne 0V ± 10 mV.</li> </ul>
<b>3</b>	<b>Contrôle du verrouillage de mise au point et du verrouillage d'axe</b>					
	V 0,5V/div	H 100 msec/div	TP1 Pin 1 (Sortie RF)		Sortie RF  Rotation dans le sens des aiguilles d'une montre	<ul style="list-style-type: none"> <li>● Charger le disc.</li> <li>● Régler le mode d'essai. (*)</li> <li>● Amener le capteur près du centre du disc en utilisant la touche DISPLAY. Toujours effectuer cette opération.</li> <li>● Observer la sortie RF à la broche 1 de TP1 avec un oscilloscope et confirmer que le signal RF est sorti lorsque la touche TRACK FWD (▶▶) est enfoncée.</li> <li>● Appuyer sur la touche PLAY (▶) et confirmer que le disc tourne dans le sens des aiguilles d'une montre à approximativement la vitesse normale (environ 300 tr/mn près du centre du disc), sans qu'il tourne irrégulièrement ou en sens inverse.</li> </ul>

\* Voir page 54.

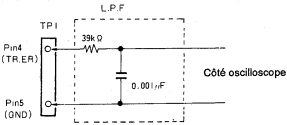
Etape No.	Réglage de l'oscilloscope		Points d'essai	Points de réglage	Éléments contrôlés/spécifications de réglage	Procédure de réglage
	V	H				
4-1	<b>Réglage du filtre (1) (avec un disc de 8 cm)</b>					
	1V/div	5 ms/div	TP1 Pin 4 (TR. ER)	Filtre	Point nul	<ul style="list-style-type: none"> <li>● Ce réglage peut être effectué avec un disc de 8 cm ayant des microcuvettes sur un rayon supérieur à 75 mm.</li> <li>● Charger le disc. (8 cm)</li> <li>● Régler le mode d'essai. (*)</li> <li>● Appuyer sur les touches TRACK FWD (▶) et PLAY (▶) dans cet ordre pour fermer les asservissements de mise au point et d'axe (l'asservissement d'alignement est en état ouvert).</li> <li>● Appuyer sur la touche DISPLAY. et amener le capteur sur la piste extérieure du disc de 8 cm. Lors du déplacement du capteur, il est possible d'insérer un tournevis dans la fente de la plaque de réglage du filtre depuis le haut de l'appareil. (Fig. 3).</li> <li>● Observer la forme d'onde à la broche 4 (TR. ER: erreur d'alignement) de TP1 avec un oscilloscope et à ce moment-là, insérer un filtre passe-bas de coupure 4 kHz (Fig. 2).</li> <li>● Insérer le tournevis d'alignement dans la fente de réglage et le tourner afin de trouver le point nul (Photo-1).</li> </ul>
	 <p style="text-align: center;">Fig. 2.</p>					

\* Voir page 54.

Etape No.	Réglage de l'oscilloscope		Points d'essai	Points de réglage	Éléments contrôlés/spécifications de réglage	Procédure de réglage
	V	H				
4-2	Réglage du filtre (2) (avec un disc de 12 cm dont la durée de lecture est supérieure à 60 minutes)					
	1V/div	5 ms/div	TP1 Pin 4 (TR. ER)	Filtre	Point nul	<ul style="list-style-type: none"> <li>● Charger le disc. (durée de lecture supérieure à 60 minutes).</li> <li>● Régler le mode d'essai. (*)</li> <li>● Appuyer sur les touches TRACK FWD (▶▶) et PLAY (▶) dans cet ordre pour fermer les asservissements de mise au point et d'axe (l'asservissement d'alignement est en état ouvert).</li> <li>● Appuyer sur la touche DISPLAY et amener le capteur sur la piste extérieure du disc. Lors du déplacement du capteur, il est possible d'insérer un tournevis dans la fente de la plaque de réglage du filtre depuis le haut de l'appareil. (Fig. 3).</li> <li>● Observer la forme d'onde à la broche 4 (TR. ER: erreur d'alignement) de TP1 avec un oscilloscope et à ce moment-à, insérer un filtre passe-bas de coupure 4 kHz (Fig. 2).</li> <li>● Insérer le tournevis d'alignement dans la fente de réglage et le tourner afin de trouver le point nul (Photo-1).</li> </ul>
				Filtre	Amplitude maximum	<ul style="list-style-type: none"> <li>● Tourner lentement l'excitateur de filtre dans le sens des aiguilles d'une montre à partir du point nul et le régler au premier point où l'amplitude de la forme d'onde (signal d'erreur d'alignement) est maximum. (Voir photo-2).</li> </ul>

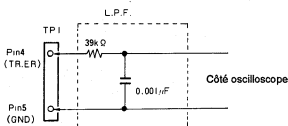

Fig. 2.

\* Voir page 54.

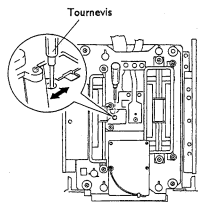

Fig. 3. Réglage du Filtre

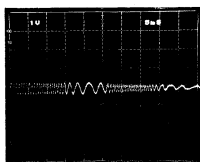

Photo-1 Point nul

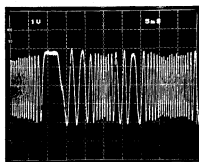

Photo-2 Amplitude maximum

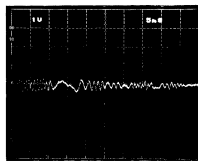
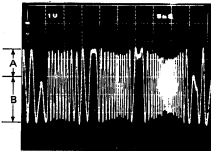

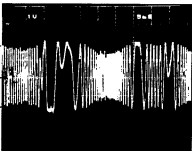

Photo-3 Hors du point nul



Etape No.	Réglage de l'oscilloscope		Points d'essai	Points de réglage	Éléments contrôlés/spécifications de réglage	Procédure de réglage
	V	H				
5	<b>Réglage de l'équilibre d'alignement</b>					
	0.5V/div	5 msec/div	TP1 Pin 4 (TR. ER)	VR5 (TR. BL)		<ul style="list-style-type: none"> <li>● Charger le disc.</li> <li>● Régler le mode d'essai. (*)</li> <li>● Appuyer sur la touche DISPLAY et amener le chariot près de la piste centrale du disc.</li> <li>● Appuyer sur les touches TRACK FWD (▶) et PLAY (▶) dans cet ordre pour faire tourner le disc.</li> <li>● Observer la forme d'onde à la broche 4 (TR. ER: erreur d'alignement) de TP1 avec un oscilloscope. Et régler VR5 (TR. BL: équilibre d'alignement) afin d'éliminer les éléments CC de la forme d'onde d'erreur d'alignement.</li> </ul>
						
	Photo-6				Photo-7	

\* Voir page 54.

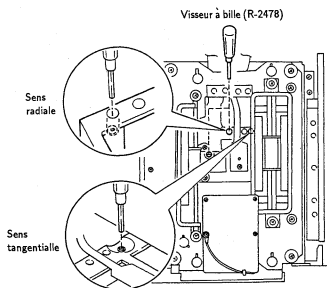

Fig. 4. Réglage Tangentiel

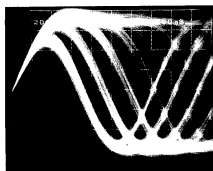

Photo-8

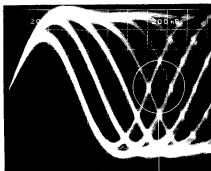

Photo-9  
Pièce à observer

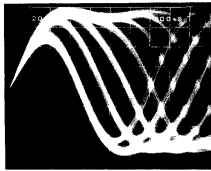
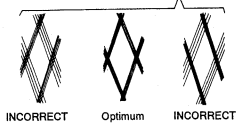

Photo-10



Etape No.	Réglage de l'oscilloscope		Points d'essai	Points de réglage	Éléments contrôlés/ spécifications de réglage	Procédure de réglage
	V	H				
6	Réglage tangentiel					<ul style="list-style-type: none"> <li>● Charger le disc.</li> <li>● Régler le mode d'essai. (*)</li> <li>● Appuyer sur la touche DISPLAY et amener le capteur à la piste centrale du disc. (Le placer à un endroit où la vis tangentielle peut être vue depuis le haut du mécanisme d'asservissement. (Voir Fig. 4.).</li> <li>● Appuyer sur les touches TRACK FWD (▶▶), PLAY (▶) et PAUSE (  ) dans cet ordre pour fermer tous les asservissements. (Le témoin de pause s'allume).</li> <li>● Observer la sortie RF broche 1 de TP 1 avec un oscilloscope et régler la vis tangentielle afin que la mire devienne claire. (Fig. 4.).</li> <li>● Le point de réglage est situé vers la position médiane entre le point où la mire devient floue lorsque la vis tangentielle est tournée dans le sens des aiguilles d'une montre et le point où la mire devient floue lorsque la vis de réglage est tournée dans le sens inverse.</li> </ul> <p>Observer la netteté d'ensemble de la forme d'onde et une des formes en diamant dans la mire (Photo-9). Le réglage optimum est obtenu au point où les lignes de la forme en diamant sont relativement fines.</p>
			TP 1 Pin 1 (Sortie RF)	Vis de réglage tangentiel	Point optimum de mire	

Fig. 5

\* Voir page 54.

Etape No.	Réglage de l'oscilloscope		Points d'essai	Points de réglage	Eléments contrôlés/spécifications de réglage	Procédure de réglage
	V	H				
7	Réglage radial		TP 1 Pin 1 (Sortie RF)	Vis de réglage radial	Point optimum de mire	<ul style="list-style-type: none"> <li>● Charger le disc.</li> <li>● Régler le mode d'essai. (*)</li> <li>● Appuyer sur la touche DISPLAY et amener le capteur à la piste centrale du disc. (Le placer à un endroit où la vis radiale peut être vue depuis le haut du mécanisme d'asservissement. (Voir Fig. 5).</li> <li>● Appuyer sur les touches TRACK FWD (▶▶), PLAY (▶) et PAUSE (■) dans cet ordre pour fermer tous les asservissements. (Le témoin de pause s'allume).</li> <li>● Observer la sortie RF broche 1 de TP 1 avec un oscilloscope et régler la vis radiale afin que la mire devienne claire. (Fig. 4.).</li> <li>● Le point de réglage est situé vers la position médiane entre le point où la mire devient floue lorsque la vis radiale est tournée dans le sens des aiguilles d'une montre et le point où la mire devient floue lorsque la vis de réglage est tournée dans le sens inverse. Observer la netteté d'ensemble de la forme d'onde et une des formes en diamant dans la mire (Photo-9). Le réglage optimum est obtenu au point où les lignes de la forme en diamant sont relativement fines.</li> <li>● Effectuer alternativement, deux fois ou plus, les réglages tangentiel et radial.</li> </ul>

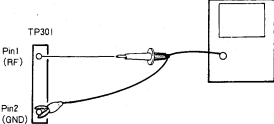
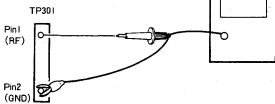

Fig. 5

\* Voir page 54.

Etape No.	Réglage de l'oscilloscope		Points d'essai	Points de réglage	Éléments contrôlés/ spécifications de réglage	Procédure de réglage
	V	H				
8	<b>Contrôle du niveau RF (fréquence radio)</b>					
			TP 1 Pin 1 (RF)	Contrôle	1,5v $\begin{smallmatrix} +0,2V \\ -0V \end{smallmatrix}$	<ul style="list-style-type: none"> <li>● Régler le mode d'essai. (*)</li> <li>● Connecter la sonde de l'oscilloscope à la sortie RF broche 1 de TP 1 .</li> <li>● Reproduire le disc, mesurer la tension c-c de la forme d'onde RF et confirmer qu'elle devient 1,5v <math>\begin{smallmatrix} +0,2V \\ -0V \end{smallmatrix}</math> .</li> <li>● Ajuster VR 10 si la tension ne devient pas 1,5v <math>\begin{smallmatrix} +0,2V \\ -0V \end{smallmatrix}</math> .</li> </ul>
			TP 1 Pin 1 (RF)	VR 10	1,5v $\begin{smallmatrix} +0,2V \\ -0V \end{smallmatrix}$	

\* Voir page 54.

Etape No.	Réglage de l'oscilloscope		Points d'essai	Points de réglage	Éléments contrôlés/ spécifications de réglage	Procédure de réglage
	V	H				
9	Réglage du gain de mise au point					<ul style="list-style-type: none"> <li>● L'alimentation étant coupée, connecter l'oscilloscope et l'oscillateur comme indiqué sur la Fig. 6.</li> <li>● Régler le mode de lecture normal.</li> <li>● Mettre l'oscillateur sous tension et le régler pour sortir un signal 1 V<sub>c-c</sub>, 1,2 kHz.</li> </ul> <p><b>Remarque:</b> (Certains oscillateurs sortent CC lorsqu'ils sont mis sous tension. Dans ce cas, connecter l'oscillateur après l'avoir mis sous tension).</p> <ul style="list-style-type: none"> <li>● Ajuster VR3 (FO. GA: gain de mise au point) afin que la forme d'onde de choc sur l'oscilloscope devienne un cercle horizontal (différence de phase 90°).</li> </ul>
	CH1 (X) , CH2 (Y) 20 mV/div, 5 mV/div (Sonde 10:1)		Axe X: TP1 Pin 5 (FO. IN) Axe Y: TP1 Pin 6 (FO. ER)	VR3 (FO. GA)	Différence de phase 90°	

Fig. 6.

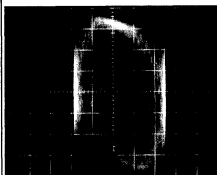

Gain élevé  
Photo-11

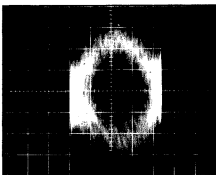

Gain optimum  
Photo-12

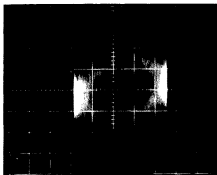

Gain faible  
Photo-13

Etape No.	Réglage de l'oscilloscope		Points d'essai	Points de réglage	Éléments contrôlés/ spécifications de réglage	Procédure de réglage
	V	H				
10	Réglage du gain d'alignement					
	CH1 (X), CH2 (Y) 50 mV/div, 5 mV/div (Sonde 10:1)		Axe X: TP1 Pin 3 (TR. IN) Axe Y: TP1 Pin 2 (TR. ER)	VR4 (TR. GA)	Différence de phase 90°	<ul style="list-style-type: none"> <li>● L'alimentation étant coupée, connecter l'oscilloscope et l'oscillateur comme indiqué sur la Fig. 7.</li> <li>● Régler le mode de lecture normal.</li> <li>● Mettre l'oscillateur sous tension et le régler pour sortir un signal 2 Vc-c, 1 kHz.</li> <li><b>Remarque:</b> (Certains oscillateurs sortent CC lorsqu'ils sont mis sous tension. Dans ce cas, connecter l'oscillateur après l'avoir mis sous tension).</li> <li>● Ajuster VR4 (TR. GA: gain d'alignement) afin que la forme d'onde de choc sur l'oscilloscope devienne un cercle horizontal (différence de phase 90°).</li> </ul>
						Fig. 7.
	 Gain élevé Photo-14	 Gain optimum Photo-15	 Gain faible Photo-16			
11	Réglage de la fréquence de relaxation du VCO (oscillateur à fréquence réglée par variation de tension)					
			TP 2 Pin 2		Fréquence 4,275 MHz ± 0,025 MHz	<ul style="list-style-type: none"> <li>● Régler le mode d'essai. (*)</li> <li>● Coupler ASY et les fils GND en utilisant un tournevis à fente ou objet similaire.</li> <li>● Connecter le fréquencemètre (gamme 10 MHz) à la broche 2 de TP 2.</li> <li>● Ajuster VR8 (VCO. A) afin que le fréquencemètre indique 4,275 MHz ± 0,025 MHz.</li> <li><b>Remarque:</b> Ajuster dans le mode d'arrêt.</li> </ul>

\* Voir page 54.  
67

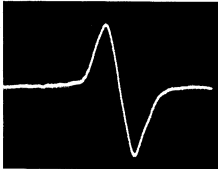
Etape No.	Réglage de l'oscilloscope		Points d'essai	Points de réglage	Eléments contrôlés/ spécifications de réglage	Procédure de réglage
	V	H				
12	<b>Contrôle d'erreur de mise au point</b>					
	1V/div	2 ms/div	TP1 Pin 6 (FO. ER)	Contrôle	Forme d'onde	<ul style="list-style-type: none"> <li>● Régler le mode d'essai. (*)</li> <li>● Connecter la broche 7 FO. IN (entrée de mise au point) de TP1 à GND.</li> <li>● Appuyer sur la touche TRACK FWD et contrôler la forme d'onde à la broche 6 FO. ER (erreur de mise au point) de TP1 avec l'oscilloscope.</li> </ul>
 <p>Erreur de mise au point Photo-17</p>						

\* Voir page 54.



## 6. AJUSTES

Realice los siguientes ajustes en el orden indicado:

### ● Ajustes

1. Ajuste de compensación del error de seguimiento, del error de foco y de RF
2. Ajuste de compensación del retorno de seguimiento
3. Comprobación de la sincronización del foco y del eje
4. Ajuste de la rejilla
5. Ajuste del equilibrio del seguimiento
6. Ajuste tangencial
7. Ajuste radial
8. Comprobación del nivel de RF
9. Ajuste de la ganancia de foco
10. Ajuste de la ganancia de seguimiento
11. Ajuste de la frecuencia propia del VCO (oscilador controlado por tensión)
12. Método de comprobación del error de foco

### ● Dispositivos de Medición

1. Osciloscopio de doble trazo
2. Medidor de potencia lumínica
3. Disco de prueba YEDS-7
4. Filtro de ajuste de foco y seguimiento
5. Filtro de paso de banda para el ajuste de la ganancia de bucle.
6. Generador de señales
7. Destornillador de la rejilla
8. Herramientas de uso general
9. Disco disponible comercialmente (de 8 cm y de 12 cm)
10. Llave hex.(GGK 1002, 1.5 mm)

### ● Modo de prueba

#### Activación y desactivación del modo de prueba

- ① Para activar el modo de prueba, ponga en ON el interruptor de alimentación con el puente del modo de prueba cortocircuitado.
- ② El modo de prueba se desactivará poniendo el interruptor de alimentación en OFF.

Las funciones de las teclas en el modo de prueba se describen en la tabla 1.

### ● Descripción de los Resistores Variables Empleados para el Ajuste

- VR2: Compensación de RF (RF. OF)  
 VR3: Ganancia de foco (FO. GA)  
 VR4: Ganancia de seguimiento (TR. GA)  
 VR5: Equilibrio de seguimiento (TR. BL)  
 VR6: Compensación del error de foco (FO. OF)  
 VR7: Compensación del error de seguimiento (TE. OF)  
 VR8: Contador de frecuencias del oscilador controlado por tensión (VCOA)  
 VR9: Compensación del retorno de seguimiento (TR. OF)  
 VR10: Nivel de RF (RF.LEV)

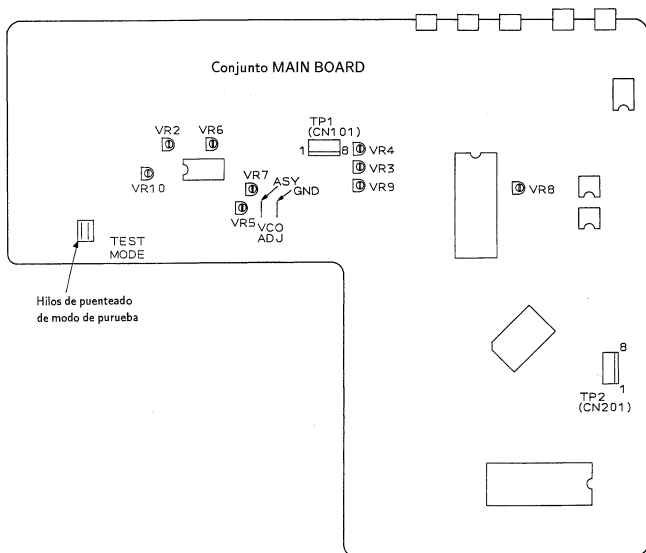
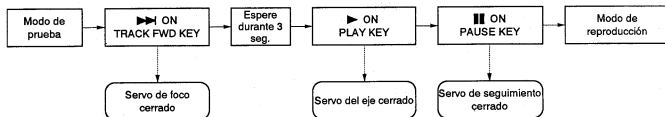

Fig.1 Punt de ajuste

En el modo de prueba, la apertura y cerrado de los servos se efectúa independientemente. Por lo tanto, para establecer el modo de reproducción se deben cerrar los servos en orden serial. Recuerde que en el modo de prueba no se puede establecer el modo de reproducción pulsando simplemente la tecla PAUSE (||).

Por ejemplo, para establecer el modo de reproducción partiendo del modo de parada pulse las teclas siguientes en el orden indicado.



\* En el modo de prueba los servos siguen un orden serial.

#### ● Función de Cada Tecla en el Modo de Prueba

Símbolo	Tecla	Función durante el modo de prueba	Explicación
▶▶	TRACK FWD	Cerrar el servo del foco	Enciende el diodo laser y mueve el actuador del foco en dirección vertical para cerrar el servo del foco.
▶	PLAY	Cerrar el servo del eje	Después de arrancar el motor del eje, cierra el servo en el modo CLV-H.
	PAUSE	Abrir/cerrar el servo de seguimiento	Ejecuta una conmutación. Al pulsar esta tecla se cierra el servo de seguimiento y la unidad entra en el modo de reproducción (los servos del foco y del eje deben estar cerrados previamente). En ese momento se enciende el indicador PAUSE. Si se la pulsa nuevamente, se abre el servo de seguimiento.
	OUTPUT	Movimiento en retroceso (hacia dentro) del carro	Mueve el carro hacia dentro a alta velocidad (aprox. 1 cm/seg.). Dado que no existe un dispositivo de seguridad que detenga el carro, asegúrese de detenerlo manualmente a tiempo.
	DISPLAY	Movimiento en avance (hacia fuera) del carro	Mueve el carro hacia fuera a alta velocidad (aprox. 1 cm/seg.). Dado que no existe un dispositivo de seguridad que detenga el carro, asegúrese de detenerlo manualmente a tiempo.
■	STOP	Parada	Detiene todos los servos y hace que la unidad vuelva a su estado inicial.
▲	OPEN/CLOSE	Abrir/cerrar la bandeja del disco	Abre y cierra la bandeja del disco. Sin embargo, el lector no vuelve a la posición de reposo cuando se abre la bandeja y tampoco se mueve al cerrarse la bandeja.

Tabla 1.

Paso	Margen del osciloscopio		Puntos de prueba	Puntos de ajuste	Item a probar/Especif. de ajuste	Procedimiento de ajuste
	V	H				
<b>1 Ajuste de compensación del error de seguimiento, del error de foco y de RF</b>						
		TP1	TP1 Pin 4 (TR. ER)	VR7 (TE. OF)	0V ± 50 mV	<ul style="list-style-type: none"> <li>● Establezca el modo de prueba (*)</li> <li>● Ajuste VR7 (TE. OF: compensación del error de seguimiento) de forma que la tensión en el contacto 4 (TE: error de seguimiento) de TP1 sea 0V ± 50 mV.</li> <li>● Ajuste VR6 (FO. OF: compensación del error de foco) de forma que la tensión en el contacto 6 (FO. ER: error de foco) de TP1 sea 0V ± 50 mV.</li> <li>● Ajuste VR2 (RF. OF: compensación de RF) de forma que la tensión de salida de RF en el contacto 1 de TP1 sea 100 mV ± 50 mV.</li> </ul>
		TP1	TP1 Pin 6 (FO. ER)	VR6 (FO. OF)	0V ± 50 mV	
		TP301	TP 1 Pin 1 (RF)	VR2 (RF. OF)	100 mV ± 50 mV	
<b>2 Ajuste de compensación del retorno de seguimiento</b>						
		TP1	TP1 Pin 2 (TR. RT)	VR9 (TR. OF)	0V ± 10 mV	<ul style="list-style-type: none"> <li>● Establezca el modo de prueba. (*)</li> <li>● Ajuste VR9 (TR. OF: compensación del retorno de seguimiento) de forma que la tensión en el contacto 2 (TR. RT: retorno de seguimiento) de TP1 sea 0V ± 10 mV.</li> </ul>
<b>3 Comprobación de la sincronización del foco y del eje</b>						
	V 0.5V/div	H 100 msec /div	TP 1 Pin 1 (Salida de RF)		Salida de RF  Rotación en sentido horario	<ul style="list-style-type: none"> <li>● Cargue el disco.</li> <li>● Establezca el modo de prueba. (*)</li> <li>● Aproxime el lector al centro del disco usando la tecla DISPLAY.</li> <li>● Asegúrese de efectuar esta operación.</li> <li>● Observe la salida de RF por el contacto 1 de TP1 con un osciloscopio y confirme que la señal de RF sea emitida al pulsar la tecla TRACK FWD (▶▶).</li> <li>● Pulse la tecla PLAY (▶) y confirme que el disco gira en sentido horario a aproximadamente la velocidad normal (unos 300 rpm por estar el lector cerca del centro del disco) sin que corra descontroladamente o en dirección inversa.</li> </ul>

\* Vea la página 69.

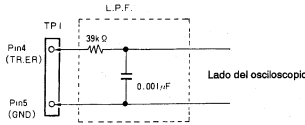
Paso	Margen del osciloscopio		Puntos de prueba	Puntos de ajuste	Item a probar/Especif. de ajuste	Procedimiento de ajuste
	V	H				
4-1	<b>Ajuste de la rejilla (1) (con un disco de 8 cm)</b>					
	1V/div	5 ms/div	TP1 Pin 4 (TR. ER)	Rejilla	Punto nulo	<ul style="list-style-type: none"> <li>● Este ajuste puede realizarse utilizando un disco de 8 cm con hoyos sobre un diámetro de 75 mm.</li> <li>● Cargue el disco. (8 cm)</li> <li>● Establezca el modo de prueba. (*)</li> <li>● Pulse las teclas TRACK FWD (▶▶) y PLAY (▶) en este orden para cerrar los servos del foco y del eje (el servo de seguimiento estará abierto).</li> <li>● Pulse la tecla DISPLAY y mueva el lector a la pista externa del disco de 8 cm. Cuando mueva el lector, será posible introducir un destornillador en la ranura de la placa de ajuste de la rejilla desde la parte de arriba de la unidad. (Fig. 3)</li> <li>● Observe la forma de la onda por el contacto 4 (TR. ER: error de seguimiento) de TP1 con un osciloscopio y, en ese momento, introduzca un filtro de corte pasabajos de 4 kHz. (Fig. 2)</li> <li>● Introduzca el destornillador de seguimiento en la ranura de ajuste y gírelo de forma que encuentre el punto nulo (Foto-1).</li> </ul>
 <p style="text-align: center;">Fig. 2.</p>						

\* Vea la página 69.

Paso	Margen del osciloscopio		Puntos de prueba	Puntos de ajuste	Item a probar/Especif. de ajuste	Procedimiento de ajuste
	V	H				
4-2	<b>Ajuste de la rejilla (2) (con un disco de 12 cm reproduciendo durante más de 60 minutos)</b>					
	1V/div	5 ms/div	TP1 Pin 4 (TR. ER)	Rejilla	Punto nulo	<ul style="list-style-type: none"> <li>● Cargue el disco (reproduciendo durante más de 60 minutos).</li> <li>● Establezca el modo de prueba. (*)</li> <li>● Pulse las teclas TRACK FWD (▶▶) y PLAY (▶) en este orden para cerrar los servos del foco y del eje (el servo de seguimiento estará abierto).</li> <li>● Pulse la tecla DISPLAY y mueva el lector a la pista externa del disco. Cuando mueva el lector, será posible introducir un destornillador en la ranura de la placa de ajuste de la rejilla desde la parte de arriba de la unidad. (Fig. 3)</li> <li>● Observe la forma de la onda por el contacto 4 (TR. ER: error de seguimiento) de TP1 con un osciloscopio y, en ese momento, introduzca un filtro de corte pasabajos de 4 kHz. (Fig. 2)</li> <li>● Introduzca el destornillador de seguimiento en la ranura de ajuste y gírelo de forma que encuentre el punto nulo. (Foto-1)</li> </ul>
				Rejilla	Amplitud máxima	<ul style="list-style-type: none"> <li>● Gire el destornillador de la rejilla lentamente en sentido antihorario a partir del punto nulo y deténgase en el primer punto donde la amplitud de la onda (señal de error de seguimiento) sea máxima. (Vea Foto-2)</li> </ul>

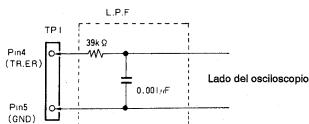

Fig. 2.

\* Vea la página 69.

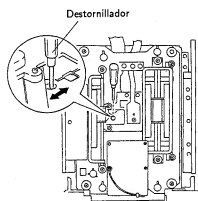

Fig. 3. Ajuste de la Rejilla



Foto-1 Punto nulo



Foto-2 Amplitud máxima

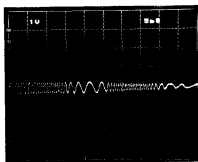

Foto-3 Fuera del punto nulo

Paso	Margen del osciloscopio		Puntos de prueba	Puntos de ajuste	Item a probar/Especif. de ajuste	Procedimiento de ajuste
	V	H				
5	<b>Ajuste del equilibrio del seguimiento</b>					
	0,5V/div	5 msec/div	TP1 Pin 4 (TR. ER)	VR5 (TR. BL)		<ul style="list-style-type: none"> <li>● Cargue el disco</li> <li>● Establezca el modo de prueba. (*)</li> <li>● Pulse la tecla DISPLAY y mueva el carro hasta cerca de la pista central del disco.</li> <li>● Pulse las teclas TRACK FWD (▶▶) y PLAY (▶) en ese orden para hacer girar el disco.</li> <li>● Observe la forma de la onda por el contacto 4 (TR. ER: error de seguimiento) de TP1 con un osciloscopio y ajuste el VR5 (TR. BL: equilibrio de seguimiento) de forma que desaparezcan los elementos de CC de la onda del error de seguimiento.</li> </ul>
						
	Foto-6		Foto-7			

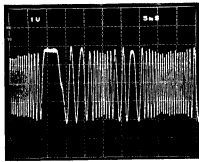
\* Vea la página 69.



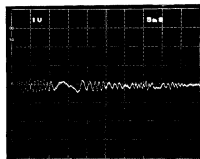
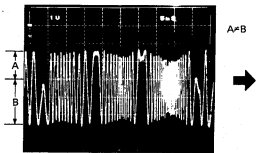
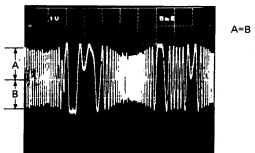
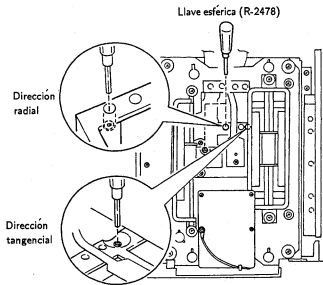

Fig. 4. Ajuste Tangencial



Foto-8



Foto-9

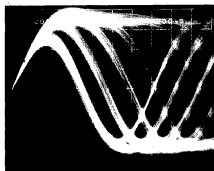

Foto-10

Parte a observar

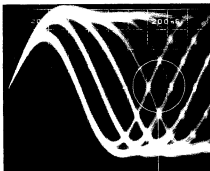

Paso	Margen del osciloscopio		Puntos de prueba	Puntos de ajuste	Item a probar/Especif. de ajuste	Procedimiento de ajuste
	V	H				
6	Ajuste tangencial		TP 1 Pin 1 (Salida de RF)	Tornillo de ajuste tangencial	Punto óptimo de la figura del ojo	<ul style="list-style-type: none"> <li>● Cargue el disco.</li> <li>● Establezca el modo de prueba. (*)</li> <li>● Pulse la tecla DISPLAY y mueva el lector a la pista central del disco (colóquelo en un lugar tal que el tornillo de ajuste tangencial pueda verse desde arriba del servomecanismo. (Vea la Fig. 4)</li> <li>● Pulse las teclas TRACK FWD (▶▶), PLAY (▶) y PAUSE (■) en este orden para cerrar todos los servos. (Se enciende el indicador de pausa).</li> <li>● Observe la salida de RF por el contacto 1 de TP 1 con un osciloscopio y ajuste el tornillo tangencial de forma que la figura del ojo se vea claramente. (Fig. 4)</li> <li>● El punto de ajuste se encuentra cerca del punto medio entre el punto donde la figura del ojo se enturbia al girar el tornillo tangencial en sentido horario y el punto donde la figura del ojo se enturbia al girar el tornillo de ajuste en sentido antihorario. Observe la claridad general de la onda y una de las figuras del diamante en la figura del ojo (foto-Ø). El ajuste óptimo se obtiene donde las líneas de la figura del diamante son relativamente delgadas.</li> </ul>

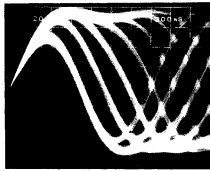
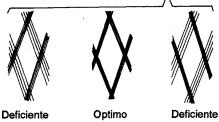
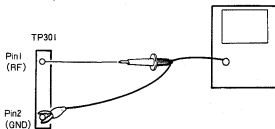

Fig. 5

\* Vea la página 69.

Paso	Margen del osciloscopio		Puntos de prueba	Puntos de ajuste	Item a probar/Especif. de ajuste	Procedimiento de ajuste
	V	H				
7	Ajuste radial					<ul style="list-style-type: none"> <li>● Cargue el disco.</li> <li>● Establezca el modo de prueba. (*)</li> <li>● Pulse la tecla DISPLAY y mueva el lector a la pista central del disco (colóquelo en un lugar tal que el tornillo de ajuste tangencial pueda verse desde arriba del servomecanismo. (Vea la Fig. 5)</li> <li>● Pulse las teclas TRACK FWD (▶▶▶), PLAY (▶) y PAUSE (▣▣▣) en este orden para cerrar todos los servos. (Se enciende el indicador de pausa).</li> <li>● Observe la salida de RF por el contacto 1 de TP 1 con un osciloscopio y ajuste el tornillo radial de forma que la figura del ojo se vea claramente. (Fig. 4)</li> <li>● El punto de ajuste se encuentra cerca del punto medio entre el punto donde la figura del ojo se enturbia al girar el tornillo radial en sentido horario y el punto donde la figura del ojo se enturbia al girar el tornillo de ajuste en sentido antihorario. Observe la claridad general de la onda y una de las figuras del diamante en la figura del ojo (foto-9). El ajuste óptimo se obtiene donde las líneas de la figura del diamante son relativamente delgadas.</li> <li>● Efectúe los ajustes tangencial y radial alternativamente dos o más veces.</li> </ul>
			TP 1 Pin 1 (Salida de RF)	Tornillo de ajuste radial	Punto óptimo de la figura del ojo	

Fig. 5

\* Vea la página 69.

Paso	Margen del osciloscopio		Puntos de prueba	Puntos de ajuste	Item a probar/Especif. de ajuste	Procedimiento de ajuste
	V	H				
8	<b>Comprobación del nivel de RF</b>					
			TP 1 Pin 1 (RF)	Comprobación	1.5V $\begin{smallmatrix} +0.2V \\ -0V \end{smallmatrix}$	<ul style="list-style-type: none"> <li>● Establezca el modo de prueba. (*)</li> <li>● Conecte la sonda del osciloscopio al contacto 1 (salida de RF) de TP 1.</li> <li>● Reproduzca el disco, mida la tensión p-p de la onda de RF y confirme que sea 1.5V <math>\begin{smallmatrix} +0.2V \\ -0V \end{smallmatrix}</math>.</li> <li>● Ajuste VR 10 si la tensión no es 1.5V <math>\begin{smallmatrix} +0.2V \\ -0V \end{smallmatrix}</math>.</li> </ul>
			TP 1 Pin 1 (RF)	VR 10	1.5V $\begin{smallmatrix} +0.2V \\ -0V \end{smallmatrix}$	

\* Vea la página 69.

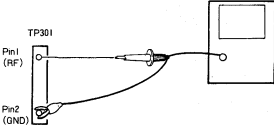
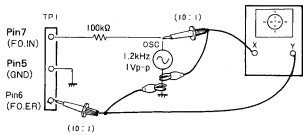
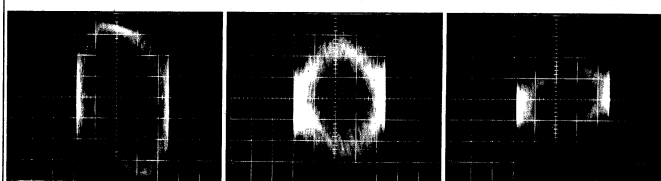
Paso	Margen del osciloscopio		Puntos de prueba	Puntos de ajuste	Item a probar/Especif. de ajuste	Procedimiento de ajuste
	V	H				
9	<b>Ajuste de la ganancia de foco</b>					
	CH1 (X) . CH2 (Y) 20 mV/div, 5 mV/div (Sonda 10:1)		Eje X: TP1 Pin 5 (FO. IN) Eje Y: TP1 Pin 6 (FO. ER)	VR3 (FO. GA)	Diferencia de fase de 90°	<ul style="list-style-type: none"> <li>● Con la unidad apagada, conecte el osciloscopio y el oscilador como muestra la Fig. 6.</li> <li>● Establezca el modo de reproducción normal.</li> <li>● Encienda el oscilador y ajústelo para que emita una señal de 1,2 kHz, 1 Vp-p.</li> </ul> <p><b>Nota:</b> Algunos osciladores emiten CC al ser encendidos. En este caso, encienda el oscilador antes de conectarlo.</p> <ul style="list-style-type: none"> <li>● Ajuste VR3 (FO. GA: ganancia de foco) de forma que la onda de resurgimiento en el osciloscopio se convierta en un círculo horizontal (diferencia de fase de 90°).</li> </ul>
						
	Fig. 6.					
						
	Alta ganancia Foto-11		Ganancia óptima Foto-12		Baja ganancia Foto-13	

Paso	Margen del osciloscopio		Puntos de prueba	Puntos de ajuste	Item a probar/Especif. de ajuste	Procedimiento de ajuste
	V	H				
10	<b>Ajuste de la ganancia de seguimiento</b>					
	CH1 (X), CH2 (Y) 50 mV/div, 5 mV/div (Sonda 10:1)		Eje X: TP1 Pin 3 (TR. IN) Eje Y: TP1 Pin 2 (TR. ER)	VR4 (TR. GA)	Diferencia de fase de 90°	<ul style="list-style-type: none"> <li>● Con la unidad apagada, conecte el osciloscopio y el oscilador como muestra la Fig. 7.</li> <li>● Establezca el modo de reproducción normal.</li> <li>● Encienda el oscilador y ajústelo para que emita una señal de 1 kHz, 2 Vp-p.</li> </ul> <p><b>Nota:</b> Algunos osciladores emiten CC al ser encendidos. En este caso, encienda el oscilador antes de conectarlo.</p> <ul style="list-style-type: none"> <li>● Ajuste VR4 (TR. GA: ganancia de seguimiento) de forma que la onda de resurgimiento en el osciloscopio se convierta en un círculo horizontal (diferencia de fase de 90°).</li> </ul>
						<p style="text-align: center;">Fig. 7.</p>
	Alta ganancia Foto-14			Ganancia óptima Foto-15		Baja ganancia Foto-16
11	<b>Ajuste de la frecuencia propia del oscilador controlado por tensión</b>					
			TP 2 Pin 2		Frecuencia 4,275 MHz ± 0,025 MHz	<ul style="list-style-type: none"> <li>● Establezca el modo de prueba. (*)</li> <li>● Ponga en derivación los puentes del ASY y GND empleando un destornillador de cabeza ranurada u otra herramienta similar.</li> <li>● Conecte el contador de frecuencias (margen de 10 MHz) al contacto 2 de TP 2.</li> <li>● Ajuste VR8 (VCO. A) de forma que en el contador de frecuencias se lea 4,275 MHz ± 0,025 MHz.</li> </ul> <p><b>Nota:</b> Ajuste con la unidad en el modo de parada</p>

\* Vea la página 69.

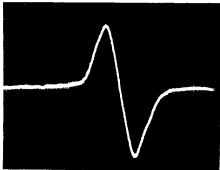
Paso	Margen del osciloscopio		Puntos de prueba	Puntos de ajuste	Item a probar/Especif. de ajuste	Procedimiento de ajuste
	V	H				
12	<b>Comprobación del error de foco</b>					
	1V/div	2 ms/div	TP1 Pin 6 (FO. ER)	Comprobación	Forma de onda	<ul style="list-style-type: none"> <li>● Establezca el modo de prueba. (*)</li> <li>● Conecte a tierra el contacto 7 (FO. IN: entrada de foco) de TP1.</li> <li>● Pulse la tecla TRACK FWD y compruebe la forma de la onda en el contacto 6 (FO. ER: error de foco) de TP1 con un osciloscopio.</li> </ul>
						
						Error de foco Foto-17

\* Vea la página 69.

## 7. IC INFORMATION

## ■ PD2028A

D/A Converter

## ● Block Diagram

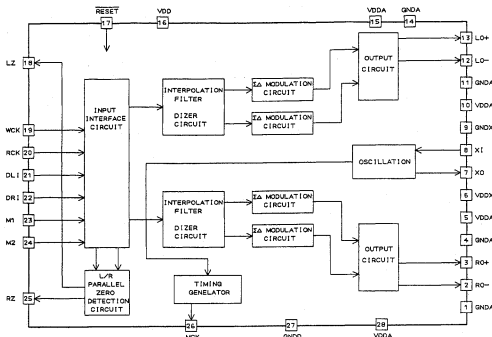

## ● Pin Function

No.	Pin name	I/O	Function
1	GNDA	—	GND terminal of D/A converter (RO-).
2	RO-	O	Data output for R ch.
3	RO+	O	Data output for R ch.
4	GNDA	—	GND terminal of D/A converter (RO+).
5	VDDA	—	Power supply input of D/A converter (RO+).
6	VDDX	—	Power supply input of Oscillator.
7	XO	O	Terminals for crystal oscillator.
8	XI	I	Generate system clock.
9	GNDX	—	GND terminal of Oscillator.
10	VDDA	—	Power supply input of D/A converter (LO-).
11	GNDA	—	GND terminal of D/A converter (LO-).
12	LO-	O	Data output for L ch.
13	LO+	O	Data output for L ch.
14	GNDA	—	GND terminal of D/A converter (LO+).

No.	Pin name	I/O	Function
15	VDDA	—	Power supply input of D/A converter (LO+).
16	VDD	—	Power supply input of logic circuit.
17	RESET	I	Reset terminal. When "L", reset the $\Sigma\Delta$ circuit.
18	LZ	O	Digital-Zero output for L ch.
19	WCK	I	Word clock input
20	BCK	I	Bit clock input
21	DLI	I	Data input for L ch.
22	DRI	I	Data input for R ch.
23	M1	I	Mode select input 1.(#1)
24	M2	I	Mode select input 2.(#1)
25	RZ	O	Digital-Zero output for R ch.
26	MCK	O	System clock output
27	GNDD	—	GND terminal of logic circuit.
28	VDDA	—	Power supply input of D/A converter (RO-).

\*1: Selection of input data.

M1(23pin)	M2(24pin)	MCK(26pin) output	OSR	Input bit rate	Applicable digital filter
0	0	384fs	384fs	20	NPC SM5803/13/40
0	1	256fs	512fs	20	NPC SM5803/13/40
1	0	256fs	256fs	20	NPC SM5803/13/40
1	1	384fs	384fs	18	SONY CXD1244/2550













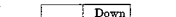

### PD3179B

Microcomputer

#### ● Pin Function

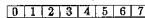
No.	Symbol	Pin name	I/O	Reset	Function
1	V <sub>SS</sub>	—	—	—	GND
2	XTAL	—	—	—	Internal clock circuit input.
3	EXTAL	—	—	—	Internal clock circuit input.
4	MP0	—	I	—	+5V
5	MP1	—	I	—	+5V
6	$\overline{\text{RES}}$	—	I	—	Reset input for CPU <u>RESET</u> <u>RUN</u>
7	$\overline{\text{STBY}}$	—	I	—	Standby input for CPU <u>STANDBY</u> <u>RUN</u>
8	$\overline{\text{NMI}}$	SCOR	I	—	Sub code sync input <u>SYNC</u>
9	P20	FOK	I	—	Focus OK <u>NG</u> <u>OK</u>
10	P21	$\overline{\text{XLT}}$	O	H	LSI data execute control pulse <u>EXEC</u>
11	SCLK	CLK	O	H	Serial transmit clock 
12	Rx	SUBQ	I	—	Sub code Q data input
13	Tx	DATA	O	H	Serial data output <u>0</u> <u>1</u> <u>2</u> <u>3</u> <u>4</u> <u>5</u> <u>6</u> <u>7</u>
14	P25	SENS	I	—	LSI running state. Multi mode input
15	P26	MUTE	O	H	Muting out (Digital block) <u>OFF</u> <u>ON</u>
16	P27	GFS	I	—	Frame sync lock <u>NG</u> <u>LOCK</u>
17	P50	$\overline{\text{LDON}}$	O	H	Laser diode On/Off <u>ON</u> <u>OFF</u>
18	P51	$\overline{\text{DEMP}}$	O	H	De-emphasis On/Off <u>ON</u> <u>OFF</u>
19	P52	$\overline{\text{TEST}}$	I	—	Test mode select input <u>TEST</u> <u>NORMAL</u>
20	P53	TMSW	I	—	Timer play switch <u>YES</u> <u>NO</u>
21	P54	AMUTE	O	H	Muting out (Analog block) <u>OFF</u> <u>ON</u>
22	P55	MDSW	I	—	Model select switch With <u>FADE</u> <u>No FADE</u>
23	P56	SYC1	I	—	Deck-Synchro input port(Pulled-up when not used)
24	P57	SYC3	O	L	Deck-Synchro output port(Open when not used)
25	P60	Not used	I	—	GND
26	P61	LIN	O	L	Disc tray loading IN/OUT output <u>Free</u> <u>Brake</u> <u>IN</u> <u>OUT</u>
27	P62	LOUT	O	L	
28	P63	LOAD	I	—	Loading complete <u>LOAD-IN</u> <u>NOT</u>
29	P64	$\overline{\text{CLOP}}$	I	—	Clamp up complete <u>CLAMP-UP</u> <u>NOT</u>
30	P65	$\overline{\text{OPEN}}$	I	—	Open complete <u>OPEN</u> <u>NOT</u>
31	P66	$\overline{\text{CLMP}}$	I	—	Clamp complete <u>CLAMP</u> <u>NOT</u>
32	P67	Not used	O	L	(OPEN)

No.	Symbol	Pin name	I/O	Reset	Function
33	V <sub>cc</sub>	-	-	-	+5V
34	P47	Not used	O	L	(Open)
35	P46	Not used	O	L	(Open)
36	P45	Not used	O	L	(Open)
37	P44	$\overline{KS}$	I	-	Key strobe input from front panel  ON OFF
38	P43	$\overline{RKS}$	I	-	Key strobe input from remote controller  ON OFF
39	P42	CLUP	O	L	Disc clamp Up/Down output  Free Brake UP
40	P41	CLDW	O	L	 Down
41	P40	STS	I	-	Input for display data transmit enable  ENABLE DISABLE
42	V <sub>ss</sub>	-	-	-	GND
43	P17	Not used	O	L	(Open)
44	P16	Not used	O	L	(Open)
45	P15	FLOF	O	H	FL display on/off  ON OFF
46	P14	$\overline{DOFF}$	O	H	Digital output status  ON OFF
47	P13	$\overline{AOFF}$	O	H	Analog output status  ON OFF
48	P12	SCK	O	H	Serial transmit clock for display data 
49	P11	SD	O	H	Serial display data output 
50	P10	SRES	O	L	Reset output for key display microcomputer  RESET RUN
51	P37	KD7	I	-	Key code input from front panel and remote controller (MSB)
52	P36	KD6	I	-	
53	P35	KD5	I	-	
54	P34	KD4	I	-	
55	P33	KD3	I	-	
56	P32	KD2	I	-	
57	P31	KD1	I	-	
58	P30	KD0	I	-	Key code input from front panel and remote controller (LSB)
59	P74	Not used	O	L	(Open)
60	P73	Not used	O	L	(Open)
61	P72	$\overline{DLAT}$	O	H	ATT level data latch pulse *1 
62	P71	DDAT	O	H	ATT level data serial output *1  0 1 2 3 4 5 6 7
63	P70	DCLK	O	H	ATT level data serial transmit clock *1  Continuous 8 pulses output.
64	E	-	O	-	(Open)

\*1: Pins 61 to 63 are connected to digital filter IC(SM5840) when it is used.

## 8. FOR HEM AND SD TYPES

### • CONTRAST OF MISCELLANEOUS PARTS

#### NOTES :

- Parts without part number cannot be supplied.
- Parts marked by "⊙" are not always kept in stock. Their delivery time may be longer than usual or they may be unavailable.
- The Δ mark found on some component parts indicates the importance of the safety factor of the part. Therefore, when replacing, be sure to use parts of identical designation.

The PD-75/HEM and SD types are the same as the PD-75/KU/CA type with the exception of the following sections.

Mark	Symbol & Description	Part No.			Remarks
		KU/CA	HEM	SD	
Δ⊙	MAIN BOARD assembly	PWZ1983	PWZ1994	PWZ1994	
Δ	PRIMARY BOARD assembly	Non supply	Non supply	Non supply	
	BALANCE BOARD assembly	Non supply	.....	.....	
⊙	FUNCTION A BOARD assembly	PWZ2000	PWZ1998	PWZ1998	
Δ	AC power cord	PDG1015	PDG1003	PDG1013	
Δ	Voltage selector	.....	.....	PSB1002	
Δ	Power transformer(17VA)	PTT1162	PTT1163	PTT1164	
Δ	Power transformer(8VA)	PTT1166	PTT1167	PTT1168	
Δ	Strain relief	CM-22C	CM-22B	CM-22B	
	25P F.F.C/30V	PDD1096	.....	.....	
	23P F.F.C/30V	.....	PDD1069	PDD1069	
	3P receptacle	PKP1004	.....	.....	
	Balance case	PNS1019	.....	.....	
	Balance cover	PAT1004	.....	.....	
	Bonnet	PEA1168	PYY1071	PYY1071	
	CD packing case	PHG1676	PHG1671	PHG1671	For Packing
	Cord with plug(mini plug)	FDE-319	.....	.....	
	FL sheet	PAM1290	PAM1251	PAM1290	
	Front panel assembly	PEA1177	PEA1178	PEA1178	
	Spacer	PNM1138	.....	.....	
	UL Caution	PRW1250	.....	.....	
	Operating instructions (German/Italian/Dutch/Swedish /Spanish/Portuguese)	.....	PRF1048	.....	

**MAIN BOARD ASSEMBLY(PWZ1994)**

The MAIN BOARD assembly (PWZ1994) is the same as the MAIN BOARD assembly (PWZ1983) with the exception of the following sections.

Mark	Symbol & Description	Part No.		Remarks
		PWZ1983	PWZ1994	
	D701-D704	1SS254	.....	
	C701	CKCYF103Z50	.....	
	C702	CCCSL101J50	.....	
	R701	RD1/6PM244J	.....	
	R702	RD1/6PM102J	.....	
	CN6	HLEM25R	HLEM23R	
	JA701, JA702	RKN1004	.....	

**PRIMARY BOARD ASSEMBLY**

The PRIMARY BOARD assemblies of PD-75/HEM and SD are the same as the PRIMARY BOARD assembly of PD-75/KU/CA with the exception of the following sections.

Mark	Symbol & Description	Part No.		Remarks
		KU/CA	HEM and SD	
	Capacitor sleeve	.....	REC-207	

**FUNCTION A BOARD ASSEMBLY(PWZ1998)**

The FUNCTION A BOARD assembly (PWZ1998) is the same as the FUNCTION A BOARD assembly (PWZ2000) with the exception of the following sections.

Mark	Symbol & Description	Part No.		Remarks
		PWZ2000	PWZ1998	
	R418, R420	RD1/6PM471J	RD1/6PM331J	
	R419	RD1/6PM391J	RD1/6PM331J	
	CN401	HLEM25R	HLEM23R	

## 9. PANEL FACILITIES

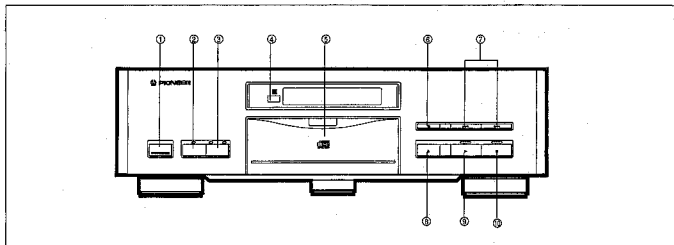

### FRONT PANEL

- ① POWER switch
- ② DISPLAY button and OFF indicator
- ③ OUTPUT button and DIGITAL/ANALOG indicators
- ④ Remote sensor  
Receives the signal from the remote control unit.
- ⑤ Disc tray
- ⑥ STOP button (■)
- ⑦ TRACK search buttons (◀◀/▶▶)
- ⑧ OPEN/CLOSE button (▲)
- ⑨ PLAY button (▶) and indicator
- ⑩ PAUSE button (⏸) and indicator

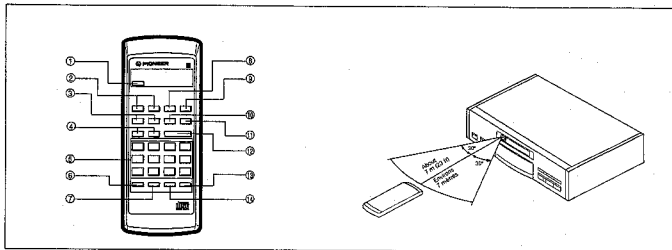

### REMOTE CONTROL UNIT

Remote control buttons with the same names or marks as buttons on the front panel of the player control the same operations as the corresponding front panel buttons.

- ① OPEN/CLOSE button (▲)
- ② INDEX buttons (←/→)
- ③ MANUAL search buttons (◀◀/▶▶)
- ④ TRACK search buttons (◀◀◀/▶▶▶)
- ⑤ Track number/Digit buttons (1-10, +10, ≧ 20)
- ⑥ PGM (Program) button
- ⑦ CHECK button
- ⑧ REPEAT button
- ⑨ RANDOM PLAY button
- ⑩ PAUSE button (⏸)
- ⑪ STOP button (■)
- ⑫ PLAY button (▶)
- ⑬ TIME button
- ⑭ CLEAR button

### REMOTE CONTROL OPERATIONS

When operating the remote control unit, point the unit's infrared signal transmitter at the remote control receiver (REMOTE SENSOR) on the front panel of the player. The remote control unit can be used within a range of about 7 meters (23 feet) from the remote sensor, and within angles of up to about 30 degrees.

#### NOTE:

If the remote control sensor window is in a position where it receives strong light such as sunlight or fluorescent light, control may not be possible.

## 10. SPECIFICATIONS

### 1. General

Type .....	Compact disc digital audio system
Power requirements	
European model .....	AC 220 - 230 V, 50/60 Hz
U.K. and Australian models .....	AC 230 - 240 V, 60 Hz
U.S. and Canadian models .....	AC 120 V, 60 Hz
Other models .....	AC 110/120 - 127/220/240 V (Switchable), 50/60 Hz
Power consumption .....	30 W
Operating temperature .....	+5°C - +35°C +41°F - +95°F
Weight .....	12.0 kg (26 lb, 7 oz)
External dimensions .....	459(W) X 330(D) X 130(H) mm 18-1/16(W) X 13(D) X 5-2/16(H) in
U.S. and Canadian models .....	459(W) X 360(D) X 130(H) mm 18-1/16(W) X 14-3/16(D) X 5-2/16(H) in

### 2. Audio section

Frequency response .....	2 Hz - 20 kHz
S/N ratio .....	112 dB or more (EIAJ)
Dynamic range .....	98 dB or more (EIAJ)
Channel separation .....	108 dB or more (EIAJ)
Harmonic distortion .....	0.0018% or less (EIAJ)
Output voltage .....	2.0V
Wow and flutter .....	Limit of measurement (±0.001% W.PEAK) or less (EIAJ)
Channels .....	2-channel (stereo)
Balanced type audio line out (U.S. and Canadian models) .....	2V (600 Ω)

### 3. Output terminal

Unbalanced type audio line output jacks	
Balanced type audio line output jacks (U.S. and Canadian models only)	
Optical and coaxial digital output jacks	
Control input/output jacks (U.S. and Canadian models only)	
CD-DECK SYNCHRO jack	

### 4. Functions

Basic operation buttons

- PLAY, PAUSE, STOP

Search function

- Direct play
- Track search
- Manual search
- Index search
- Time location

Programming

- Maximum 24 steps
- Pause
- Program check/correction
- Program clear (single track or all tracks)

Repeat functions

- 1 track repeat
- All tracks repeat
- Program play repeat
- Random play repeat
- Program random play repeat

Random play (repeat also available)

Switching display

Time consumed, remaining time (track/disc), and total time

Timer start

### 5. Accessories

● Remote control unit .....	1
● Size AAA/R03/dry batteries .....	2
● Turntable sheet .....	1
● Control cord (U.S. and Canadian models only) .....	1
● Output cable .....	1
● Operating instructions .....	1

#### NOTE:

Specifications and design subject to possible modification without notice, due to improvements.